

Gas Sample Probe Series SP[®]

SP2000, SP2000-H, SP2300-H, SP2400-H serial number 10283 and higher

Instruction Manual
Version 1.00.01

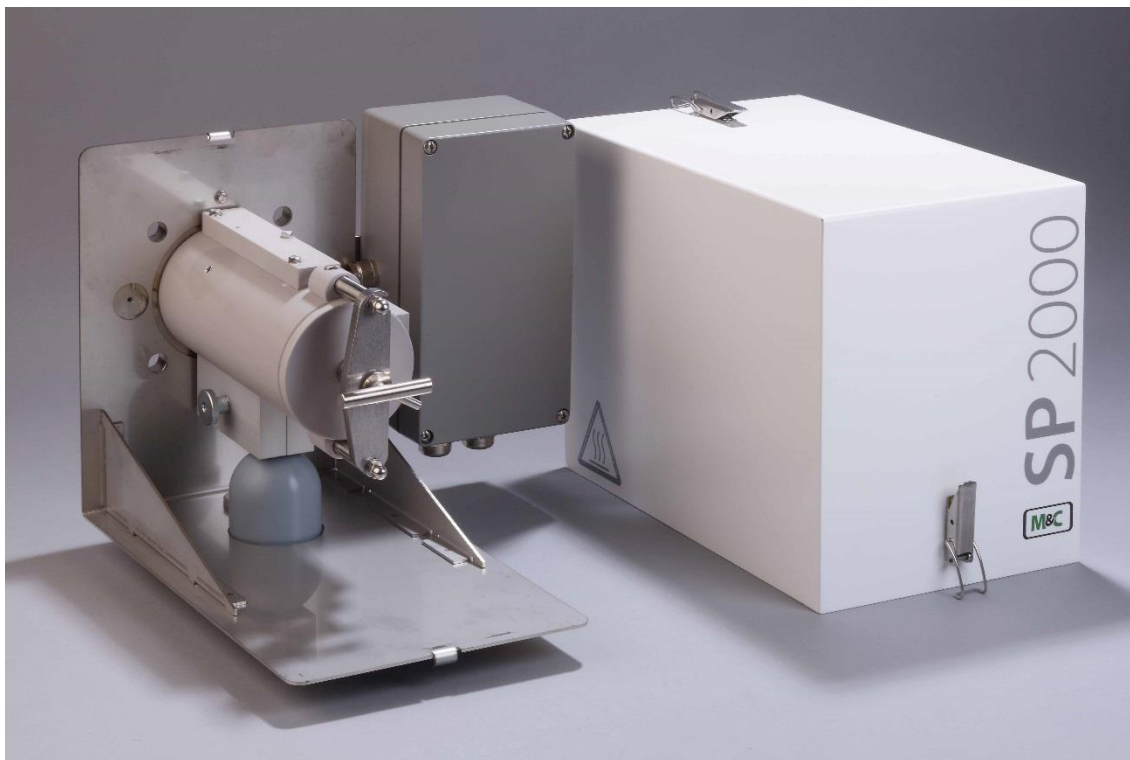

Contents

1	General information	5
2	Declaration of conformity	5
3	Safety instructions	6
4	Warranty	6
5	Used terms and signal indications	7
6	Introduction	8
7	Serial numbers	8
8	Technical Data	9
9	Application	10
10	Description	10
11	Probe design of the heated version	11
11.1	Sample gas connection.....	11
11.2	Temperature controller.....	12
11.3	Sample tube and prefilter possibilities.....	12
12	Receipt of goods and storage	14
13	Preparation for Installation	15
14	Mounting	16
14.1	Check of the filter element.....	16
14.2	Mounting of the screwed connector at the sample outlet.....	18
14.3	Mounting of probe with sample tube or prefilter.....	18
14.4	Mounting of sample line.....	21
14.5	Connection of option test gas feeding or blow back line.....	22
14.6	Connection option pneumatic drive MS1 or MS3.....	23
15	Electrical connections	23
15.1	Standard Version with Internal Capillary Tube Thermostat.....	23
15.2	Version with PT100 or thermocouple (option).....	24
16	Starting	26
16.1	Gas sample probe SP2300-H.....	27
16.2	Option calibration gas feeding and blow back.....	27
16.2.1	Option check valve /R.....	27
16.2.2	Via 3/2 way ball valve /3VA.....	28
16.3	Option ball valve drives.....	29
16.3.1	Option Pneumatic drive MS1 or MS3 when using a 2/2-way ball valve /VA.....	29
16.3.2	Option Pneumatic drive MS1 or MS3 when using a 3/2-way ball valve /3VA.....	30
16.3.3	Option Electrical ball valve drive.....	31
16.4	Option solenoid valve units for blow back, test gas feeding and control of the pneumatic drives.....	31
16.4.1	Option drive unit 234B for the solenoid valve units.....	34
17	Maintenance	36
17.1	Changing filter element and checking sealings.....	37
17.2	change of the optional prefilter.....	39
17.3	Change of heating cartridge and thermostat.....	39
18	Switching Off	42
19	Spare part list	42
20	Connection and mounting data	43
21	Appendix	44

List of illustrations

Figure 1	Design of basic version SP2000-H.....	11
Figure 2	Mounting possibilities SP2000..., SP2300-H, SP2400-H.....	15
Figure 3	Cross-sectional drawing SP2000-H.....	16
Figure 4	Removing the new filter housing lid.....	17
Figure 5	Mounting of screwed connector at sample outlet.....	18
Figure 6	Mounting of sample tube or prefilter.....	20
Figure 7	Mounting of heated sample line.....	21
Figure 8	Connection test gas feeding or blow back line.....	22
Figure 9	Electrical connection for SP2000-H, SP2300-H and SP2400-H with thermostat controller.....	24
Figure 10	Electrical connection of external temperature controller e.g. 70304G.....	25
Figure 11	Electrical connection electronic controller 70304G.....	26
Figure 12	Calibration gas feeding.....	28
Figure 13	Pneumatic drive for 2/2-way ball valve.....	29
Figure 14	Pneumatischer Antrieb für 3/2-Wege Kugelhahn.....	30
Figure 15	Electrical connection for electrical ball valve drive.....	31
Figure 16	Connections solenoid valve unit 2.....	32
Figure 17	Connections solenoid valve unit 3.....	33
Figure 18	Wiring plan of control unit 234B.....	36
Figure 19	Filter elements and gaskets.....	38
Figure 20	Position of Thermostat and heating cartridge.....	40
Figure 21	Position of fixing screws of connection box, thermostat sensor and heating cartridge carrier plate.....	40
Figure 22	Dismounted electrical connection box with heating cartridge and thermostat sensor.....	41
Figure 23	Adjustment of the mechanical stop at the thermostat controller.....	41
Figure 24	SP2000-H basic version.....	45
Figure 25	SP2000-H with options.....	46
Figure 26	High temperature tube aluminium oxide AO.....	47
Figure 27	Heated sample tubes SP30-H.....	48
Figure 28	Test gas feeding and blow back possibilities.....	50
Figure 29	SP2000-H/3VA/MS-NC-B.....	51
Figure 30	SP2000-H/3VA/MS-NC-C.....	52
Figure 31	SP2000-H/3VA/MS-NO-B.....	53
Figure 32	SP2000-H/3VA/MS-NO-C.....	54



Dear customer,

we have made up this operating manual in such a way that all necessary information about the product can be found and understood quickly and easily.

Should you still have any question, please do not hesitate to contact **M&C** directly or go through your appointed dealer. Respective contact addresses are to be found in the annexe to this operating manual. Please also contact our homepage www.mc-techgroup.com for further information about our products. There, you can read or download the data sheets and operating manuals of all **M&C** products as well as further information in German, English and French.

This Operating Manual does not claim completeness and may be subject to technical modifications.

© 04/2016 **M&C TechGroup** Germany GmbH. Reproduction of this document or its content is not allowed without permission from **M&C**.

SP® is a registered trade mark.

Version: 1.00.01

Head Office

M&C TechGroup Germany GmbH ♦ Rehhecke 79 ♦ 40885 Ratingen ♦ Germany

Telephone: 02102 / 935 - 0

Fax: 02102 / 935 - 111

E - mail: info@mc-techgroup.com

www.mc-techgroup.com

1 GENERAL INFORMATION

The product described in this operating manual has been examined before delivery and left our works in perfect condition related to safety regulations. In order to keep this condition and to guarantee a safe operation, it is important to heed the notes and prescriptions made in this operating manual. Furthermore, attention must be paid to appropriate transportation, correct storage, as well as professional installation and maintenance work.

All necessary information a skilled staff will need for appropriate use of this product are given in this operating manual.

2 DECLARATION OF CONFORMITY

CE - Certification

The product described in this operating manual complies with the following EU directives:

EMV-Instruction

The requirements of the EU directive 2014/30/EU “Electromagnetic compatibility” are met.

Low Voltage Directive

The requirement of the EU directive 2014/35/EU “Low Voltage Directive” are met.
The compliance with this EU directive has been examined according to DIN EN 61010.

Declaration of conformity

The EU Declaration of conformity can be downloaded from the **M&C** homepage or directly requested from **M&C**.



3 SAFETY INSTRUCTIONS

Please take care of the following basic safety procedures when mounting, starting up or operating this equipment:

Read this operating manual before starting up and use of the equipment. The information and warnings given in this operating manual must be heeded.

Any work on electrical equipment is only to be carried out by trained specialists as per the regulations currently in force.

Attention must be paid to the requirements of VDE 0100 (IEC 364) when setting high-power electrical units with nominal voltages of up to 1000 V, together with the associated standards and stipulations.

Check the details on the type plate to ensure that the equipment is connected to the correct mains voltage.

Protection against touching dangerously high electrical voltages:

Before opening the equipment, it must be switched off and hold no voltages. This also applies to any external control circuits that are connected.

The device is only to be used within the permitted range of temperatures and pressures.

Check that the location is weather-protected. It should not be subject to either direct rain or moisture.

The equipment must not be used in hazardous areas.

Installation, maintenance, monitoring and any repairs may only be done by authorized personnel with respect to the relevant stipulations.

4 WARRANTY

If the equipment fails, please contact **M&C** directly or else go through your **M&C** authorised dealer.

We offer a one year warranty as of the day of delivery as per our normal terms and conditions of sale, and assuming technically correct operation of the unit. Consumables are hereby excluded. The terms of the warranty cover repair at the factory at no cost or the replacement at no cost of the equipment free ex user location. Reshipments must be send in a sufficient and proper protective packaging.

5 USED TERMS AND SIGNAL INDICATIONS



DANGER!

This means that death, severe physical injuries and/or important material damages **will occur** in case the respective safety measures are not fulfilled.



WARNING!

This means that death, severe physical injuries and/or important material damages **may occur** in case the respective safety measures are not fulfilled.



CARE!

This means that minor physical injuries **may occur** in case the respective safety measures are not fulfilled.

CARE!

Without the warning triangle means that a material damage **may occur** in case the respective safety measures are not met.

ATTENTION!

This means that an unintentional situation or an unintentional status **may occur** in case the respective note is not respected.



NOTE!

These are important information about the product or parts of the operating manual which require user's attention.

SKILLED STAFF

These are persons with necessary qualification who are familiar with installation, use and maintenance of the product.

6 INTRODUCTION

Major problems of the extractive continuous gas analysis are the materials contained in the sample gas e.g. dust, water vapour and also gas components forming corrosive acids with condensing water vapour.

In order to realize an easy-to-maintain measurement the dust has to be separated without condensation of water vapour. This prevents „baking“ of dust and water and the possible acid formation. This way a blockage of filters and connected line is prevented and the probe material in contact with the gas will not be affected.

The solution are heated **M&C** sample probes like e.g. probes of the series **SP2000...** This probes guarantee a minimum of maintenance work if correctly adapted to the process conditions. At the continuous gas sampling for analytical measurements with **M&C** gas sample probes a fine dust filtration already happens at the sample point. Hereby already a majority of necessary maintenance work at analyser systems is prevented.

Basically, the quantity of sampled gas should be kept to a necessary minimum to guarantee a minimum of maintenance work and a maximum of availability. This is made possible thanks to optimised downstream gas conditioning using **M&C** components.

7 SERIAL NUMBERS

The nameplates bearing the serial number are located on the side of the electrical connection box.



NOTE!

Always quote the device's serial number when making enquiries and ordering replacement parts.

8 TECHNICAL DATA

Gas sample probe type	SP2000	SP2000-H	SP2300-H	SP2400-H
Part no.	20S1000	20S2000	20S3000	20S3500
Weather protection shield	no	yes	yes	yes
Protection class terminal box	IP54 EN60529			
Material filter housing	Stainless steel SS316/316Ti*		PTFE	Titanium
Sealing material	FPM* /7aT** = PTFE -H320/C** = Graphite			
Probe flange sealing material	Novapress			
Insitu probe tube / prefilter	Optional			
Sample pressure max.	0,4-6 bar* abs., /7aT** = 2 bar abs., /HP** = 25 bar abs.		2 bar abs.	0,4-6 bar abs.
Ambient temperature	20 °C to +180 °C	-20 °C to +60 °C*; /PT100, /Fe-CuNi, /Ni-CrNi** = -20°C to +80°C		
Filter chamber volume	120 cm ³			
Filter porosity	S-2K150= ceramic*, 2micron, /F-0, 1GF150= glass fibre**, 0,1 micron, /F-3SS150= stainless steel**, 3 micron, /FW= spun glass**			
Thermostat, temperature adjustment		0-180°C* -H320/C**= 0-320°C /PT100** /Fe-CuNi** /Ni-CrNi**		
Ready for operation		after 40min -H320/C** = after 60min		
Low temperature alarm contact*		contact rating: 250V, 3A~, 0,25A= alarm point: ΔT 30°C		
Sample gas outlet connection	1x 1/4" NPTi* tube connection** ø 6, 8 or 10mm -H320/C**= tube connection 6mm or 8mm*			
Backflush/Test gas connection	1/4" NPTi* /R**, -H320/C**= tube ø 6 mm			
Power supply		230V 50/60 Hz, 800W /115V** = 115V 60Hz, 800W (fuse protection 10A)		
Electrical connections		Terminals max. 4mm ² , 2 x cable gland PG 13,5		
Electrical equipment standard		EN 61010, EN 60519-1		
Mounting flange	DN65 PN6, form B >DN or ANSI possible** /HP** = DN50 PN25			
Mounting flange material	SS316Ti		PTFE	Titanium
Weight	7 kg*	15,4 kg*	15,4 kg*	14,5kg*

* = Standard

** = Optional

Differential pressure and T90-time at different flow rates							
ΔP and T90 at flow of	100	200	500	1000	1500	3000 (only /HF)	NI/h
ΔP with new filter element S-2K 150/F-0,1GF150	0,007	0,011	0,020	0,058	0,135	0,240/0,225	bar
ΔP with new filter element F-3SS150	0,006	0,012	0,040	0,110	0,215	0,405	bar
T90-time without sample tube/pre-filter	6,0	3,5	1,0	<0,5	<0,5	<0,5	sec.

9 APPLICATION

The **M&C** gas sample probes type **SP2000...**, **SP2300-H** and **SP2400-H** are used for continuous extraction of gases from dust laden, high-temperature and/or humid processes.

10 DESCRIPTION

The sample probes are designed for easy installation, reliable and flexible operation and trouble-free maintenance. Depending on the problem, different sample tubes or prefilters (see data sheet 2-1.1.0.6 and 2-1.1.0.8) are screwed into the thread (G3/4") in the mounting flange. This equipment is not included in the scope of delivery of the probe.

The large-surface ceramic deep filter element (fibre glass or glass wadding fillings are also available) is placed in a housing with small dead volume outside the process area. The probes are designed so that no tools are necessary for changing the filter element, the sample line needs not to be dismantled and no contamination on the clean gas side will occur. Cleaning or back purging of the sample tube is possible from outside. Due to the special execution of the heating element of the **SP2000-H**, **SP2300-H** and **SP2400-H** (with protection cover), the complete filter housing including mounting flange is heated, adjustable up to 180°C (version H320/C up to 320°C), so that a safe operation without shortfall below the dew point in the out-of-process area is guaranteed. The temperature adjustment of the standard version is made via an integrated capillary sensor thermostate with excess temperature limiter and alarm function in compact configuration. Calibration gas feeding and comparison sampling at the probe are possible. Depending on the gas composition, it may be possible that the standard material of the probe body (stainless steel 1.4404) is not sufficient with respect to its corrosion resistance. For this case, the **SP2300-H** of PTFE is available or alternatively for a heating above 180°C the **SP2400-H** out of Titane.

The following filter elements are available:

Filter elements	Type	Porosity	Material
Filter element	S-2K 150	2µm	Ceramic*
Filter element	S-3G 150	3µm	Glass
Filter element	S-3SS 150	3µm	Stainless steel SS316
Filter element	S-0,1GF 150	0,1µm	Glass fiber
Filter element	FW	-----	Spun glass

* = Standard

The following sealing agents are applied:

Material	Type	Max. temperature
Viton	Standard	max. 180°C
PTFE	Type /7aT	max. 180°C
Graphite	Type -H320/C	max. 320°C

The following types of partial filter heating and regulation are possible:

Type	Version
-H	Electrical heating and control with incorporated capillary thermostat*
/PT100 /Fe-CuNi /Ni-CrNi	Electical heating and control with external electronic temperature controller
/D	Steam heating, not controlled

* = Standard

11 PROBE DESIGN OF THE HEATED VERSION

A complete gas sample probe consists of the heated filter part and a sample tube or prefilter. The filter housing with its all-round heating element ① forms a unit with the standard mounting flange DN65 PN6 ② and the laterally mounted electrical connection box ③.

The heat-insulated shield is mounted on the stainless steel angle ④ sheet which is mounted on the mounting flange. It is secured with 2 pressure clamps. The cover ensures a uniform distribution of heat over the probe heater and at the same time serves as protection against weather and accidental contact.

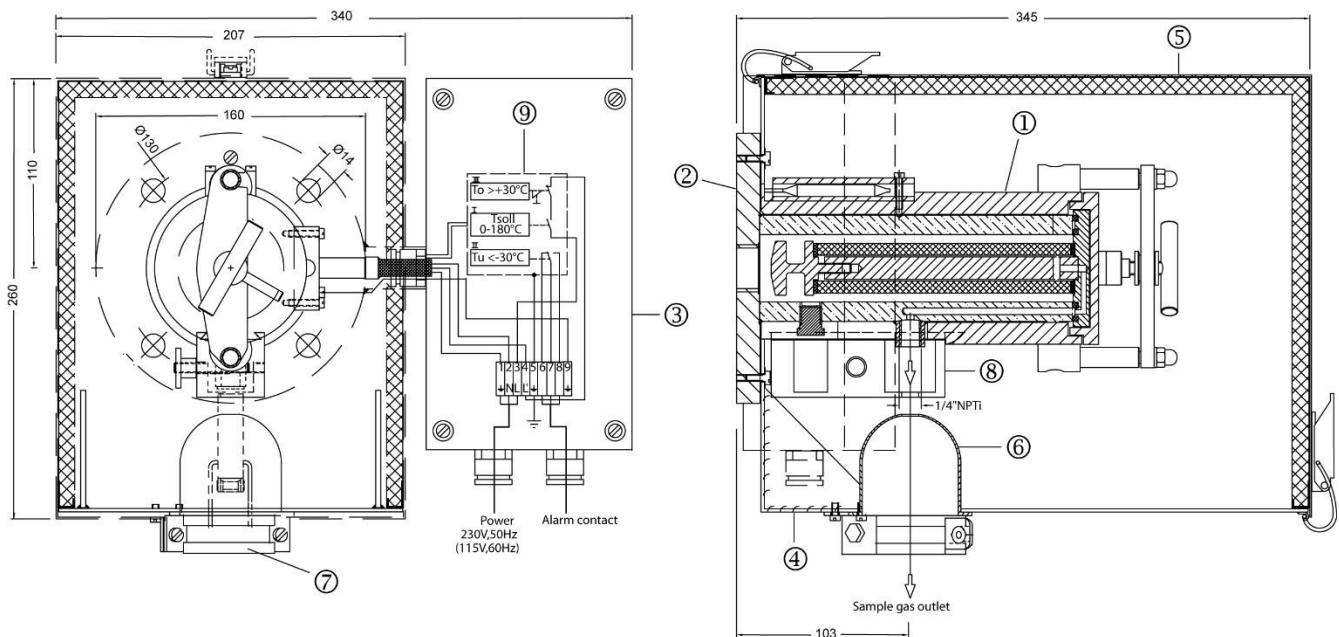

Figure 1 Design of basic version SP2000-H

11.1 SAMPLE GAS CONNECTION

The connecting clamp ⑦ for attaching heated **M&C** sample lines with external dimensions of between 40mm and 50mm is located at the aperture on the underside of the angle sheet, which is closed with a silicon lid ⑥. The clamp is mounted on an adjustable mounting bracket which allows adjustment for various sample line diameters.

The standard probe's sample gas outlet connection has a 1/4" NPT internal thread to which the customer must connect a suitable size of temperature resistant and threaded connector to connect the sample line in a gas tight manner. These connectors can be supplied by **M&C**.

In the high-temperature version **-H320/C...**, the sample gas outlet connection is fitted with a welded 6 mm threaded pipe connection (optional 8mm).

After the threaded pipe connector and sample line have been mounted, the sample gas outlet connection is enclosed in special heat-conducting jaws ⑧ in order to avoid temperature failures in the critical connection areas. The size of the heat-conducting jaws allows connection joints up to an external pipe dimension of 10mm.

11.2 TEMPERATURE CONTROLLER

In standard version **-H**, or with option **-H320/C** temperature control is ensured by way of the capillary tube thermostat which is built into the connection box and which has a regulation range between 0°C to 180°C (**-H**) or 0°C to 320°C (**-H320/C**). Rated values can be set to a maximum 180°C resp. 320°C. The temperature has an excess temperature limiter which permanently switches off the heating if the set temperature is exceeded by 30°C. The heating can be switched back on again by pressing the green RESET-button which is located below the aperture in the thermostats mounting.

The thermostat has a temperature failure alarm which activates a contact if the temperature falls 30°C below the set temperature. This status alarm is located on the terminal strip as a potential-free switch over contact.

If temperature control is to be achieved using external electronic equipment, a PT100 (a max. of two can be built in) or an Fe-CuNi resp. Ni-CrNi thermoelement is provided as a temperature sensor.

M&C also supplies suitable temperature controller, e.g. Type **70304G** (see data sheet 2-5.1) which also can be mounted directly at the gas sample probe (max. ambient temperature +45°C).

11.3 SAMPLE TUBE AND PREFILTER POSSIBILITIES

Depending on the process gas temperature and composition, probe tubes made of different materials are used with 3/4" connections.

Sample tube Type	Part no.	Temperature max. °C	Material tube / connection part	Length ¹⁾ mm	Length max. mm	Tube ø o/i „d1“ mm
SP2000/PV	20S9070	90	PVDF/ PTFE-GV	1000	1500	25/21
SP32**	20S9280	90	PVDF/ PTFE-GV	800	800	50/44
SP2000/T	20S9083	160	PTFE/ PTFE-GV	500	500	25/15
SP2000/Ti	20S9075	400	Titanium	1000	2500	25/22
SP210/SS	02S9200	600	SS316Ti	1000	2000	12/10
SP2000/SS	20S9065	600	SS316Ti	1000	2500	25/22
SP2000/SS-Vm	20S9067	600	SS316Ti	1000	2500	25/06
SP2000/HC	20S9090	900	Hastelloy C4	1000	2500	25/22
SP2000/KA	20S9080	1300	Kanthal / SS316Ti	1000	1500	27/20
SP2000/IN	20S9077	1100	Inconel	1000	2000	25/22
SP2000/CR-2*	20S9098	1400	Cr AL ₂ O ₃ / Hastelloy C4	900	900	22,5/13
SP2000/CR-20*	20S9099	1400	Cr AL ₂ O ₃ / Hastelloy C4	1200	1200	22,5/13
SP2000/AO + ↓	20S9385	1800	Aluminiumoxide ²⁾ /	1000	1500	24/18
Adapter	20S9395	(600)	/ SS316Ti			
Adapter	20S9397	(900)	/ Hastelloy C4			

* Sample tube with support adapter. Max. Temperature concern the area of the support adapter on approx. 200 mm length depend on material 600/900 °C.

** For gas sampling downstream wet scrubbers for droplet separation

¹⁾ standard

²⁾ Please pay attention to the characteristic feature of ceramic in case of high and changing temperatures!

Other materials or executions on request.

For more information about sample tubes see data sheet 2-1.1.0.6

To prevent condensation between sample point and heated gas sample probe or in case of condensation in the area of the connection piece heated sample tubes made of stainless steel with flange connection DN65 PN6 are used.

Type	Max. process temperature	Length max.	Tube ø o.	Temperature sensor
SP-30H1.1, heating max. 320°C	bis max. 550 °C	2,0 m *	ø 42,2mm	Fe-CuNi
SP-30H1.1V, heating max. 320°C	bis max. 550 °C	2,0 m *	ø 42,2mm	Fe-CuNi
SP30-H2, heating max. 320°C	bis max. 550 °C	2,0 m *	ø 42,2mm	PT100
SP35-H1.1, heating max. 320°C	bis max. 550 °C	0,175 m	ø 42,2mm	Fe-CuNi
SP35-H2, heating max. 320°C	bis max. 550 °C	0,175 m	ø 42,2mm	PT100

* = standard

For more information about heated sample tubes see data sheet 2-1.9.5

In case of heavier dust loading of the process gas, we recommend using a prefilter under all circumstances in order to prolong service life. This can be supplied with or without dead volume displacer depending on the response times required. These filters can be screwed directly into the probe flange or via extension tubes fitted with volume displacers.

The following prefilters can be selected :

Prefilter Type	Part no.	Temp. max. °C	Material filter / connection	Filter porosity µm	Dust content g/m ³	Inside volume displacer	Length mm	Filter ø mm	Connection
SP2000/20SS 150	20S9160	600	SS316/316Ti	20	2-10		150	31	ø 25
SP2000/V20	20S9085	600	SS316/316Ti	2	2-10		220	46	G 3/4"a
SP2000/V20-0	20S9105	600	SS316/316Ti	2	2-10	X	220	46	G 3/4"a
SP2000/V20/HC	20S9095	900	Hastelloy-C	2	2-10		220	46	G 3/4"a
SP2000/V20-0/HC	20S9115	900	Hastelloy-C	2	2-10	X	220	46	G 3/4"a
SP2000/V20-T	20S9315	200	PTFE / SS316Ti	3	> 10		400	65	G 3/4"a
SP2000/V20-2	20S9125	600	SS316/316Ti	2	> 10		520	60	G 3/4"a
SP2000/V20-1	20S9145	600	SS316/316Ti	2	> 10	X	520	60	G 3/4"a
SP2000/V20-2/HC	20S9135	900	Hastelloy-C	2	> 10		520	60	G 3/4"a
SP2000/V20-1/HC	20S9155	900	Hastelloy-C	2	> 10	X	520	60	G 3/4"a
SP2000/V20-4 ¹⁾	20S9290	600	SS316/316Ti	2	2-10		¹⁾ 300	31	G 3/4"a
SP2000/V20-3 ¹⁾	20S9300	600	SS316/316Ti	2	2-10	X	¹⁾ 300	31	G 3/4"a
SP2000/V20-5	20S9127	500	SS316/316Ti	3	2-10		220	50	G 3/4"a
SP2000/V20-6	20S9128	500	SS316/316Ti	3	> 10		520	60	G 3/4"a
SP2000/V12-1	20S9500	1000	Keramik ⁵⁾ / SS316Ti	1	> 10		500	40	DN65 PN6
SP2000/V12-3	20S9510	1000	Keramik ⁵⁾ / SS316Ti	1	> 10	optional	1000	60	DN65 PN6
SP2000/V12-2	20S9505	1000	Keramik ⁵⁾ / SS316Ti	2	> 10	optional	1000	60	DN65 PN6
SP2000/V12-1/SS ²⁾	20S9525	600	Keramik ⁵⁾ / SS316Ti	1	> 10		500	40	DN65 PN6
SP2000/V12-3/SS ³⁾	20S9535	600	Keramik ⁵⁾ / SS316Ti	1	> 10	optional	1000	60	DN100 PN6
SP2000/V12-2/SS ³⁾	20S9530	600	Keramik ⁵⁾ / SS316Ti	2	> 10	optional	1000	60	DN100 PN6
SP2000/V12-1/IC ²⁾	20S9540	1000	Keramik ⁵⁾ / Incoloy-SS316Ti	1	> 10		500	40	DN65 PN6
SP2000/V12-3/IC ³⁾	20S9550	1000	Keramik ⁵⁾ / Incoloy-SS316Ti	1	> 10	optional	1000	60	DN100 PN6
SP2000/V12-2/IC ³⁾	20S9545	1000	Keramik ⁵⁾ / Incoloy-SS316Ti	2	> 10	optional	1000	60	DN100 PN6

¹⁾ Prefilter V20-3, V20-4 optional up to 1000 mm length available.

²⁾ With protection tube V12-1.

³⁾ With protection tube V12-2/3.

⁴⁾ Prefilter with special construction for efficient back purge.

⁵⁾ Please pay attention to the characteristic feature of ceramic in case of high and changing temperatures!

For more information about prefilters see data sheet 2-1.1.0.8

12 RECEIPT OF GOODS AND STORAGE

- The gas sample probe and any special accessories should be removed carefully from the packaging and checked immediately for completeness against the delivery note.
- Check the goods for any damage incurred during transport and if necessary inform your transport insurer of any damage.

The gas sample probe is normally delivered in two packaging units:

1. The gas sample probe with the screws, nuts and flange seal required for mounting.
2. Sample tube or prefilter, if applicable with extension tube.

**NOTE!**

The equipment should be stored in a protected, frost-free room!

13 PREPARATION FOR INSTALLATION

- Select the optimal sampling point in accordance with the generally applicable guidelines or consult the competent persons.
- Locate the sampling point in such a way that there is adequate space for inserting and removing the probe and pay attention to the insertion length of the probe tube.
- Make certain that the probe is easily accessible so that you can carry out any subsequent maintenance work without trouble.
- Locate the probe connections in such a way that the connections' temperature is always above the acid dew point in order to avoid corrosion and blockage problems. If this is not possible, a heated **SP35/SP30** probe tube is recommended for cold connections.
- If the ambient temperature in the area of the connections is $>80^{\circ}\text{C}$ as a result of radiated heat, then a radiated-heat deflector must be mounted to protect the probe.
- The connection's mounting flange connection should comply with DN65 PN6. If other connection sizes are required, a special adapter flange **/S010** can be supplied as an option. Instead of flange connection mounting, the probe can also be mounted using an R2" adapter on a corresponding threaded sleeve connection. This adapter can be supplied. The necessary minimum flange size and the minimum connection diameter depends on the diameter of the probe tube or prefilter used.

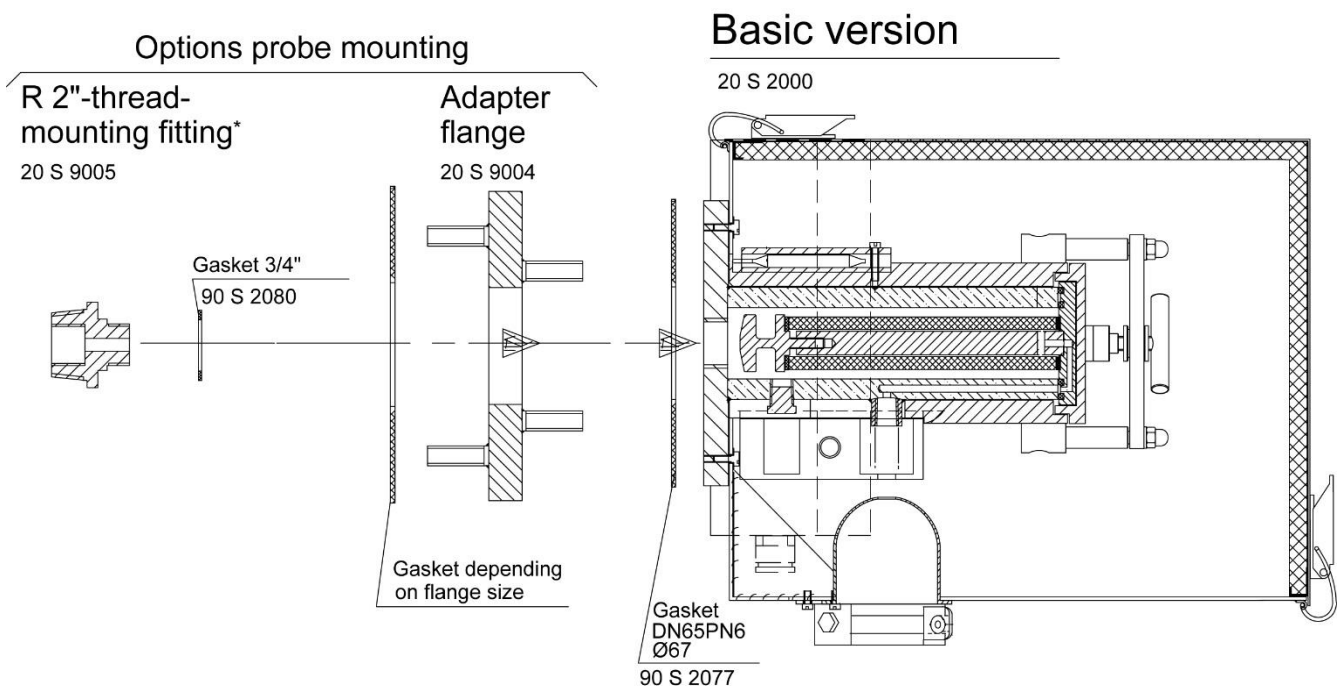

Figure 2 Mounting possibilities SP2000..., SP2300-H, SP2400-H

Before mounting, the probe must be adjusted to the existing operating conditions.

The existing operational parameters are to be checked accordingly prior to commencing mounting work.

Low-excess pressure situation	mbar	bar	
Process temperature	°C, Min.	°C Max.	
Dust loading	g/m ³		
Dust composition – grain size	µm		
Gas composition	corrosive	toxic	explosive
Parameters to be measured, e.g. O ₂ , CO, SO ₂ , NO _x ,...	Vol. %	mg/Nm ³	ppm
Necessary gas flow	l/hr, Min.	l/hr, Max.	
Necessary T ₉₀ -time	s		

14 MOUNTING

M&C SP2000 probes are designed for stationary use and if properly selected and mounted a long service life and minimum maintenance are guaranteed.

It is advisable to mount the probe in an operational position which is at a 10% inclination to the process.

14.1 CHECK OF THE FILTER ELEMENT

Before starting the filter element has to be checked for tight fit.

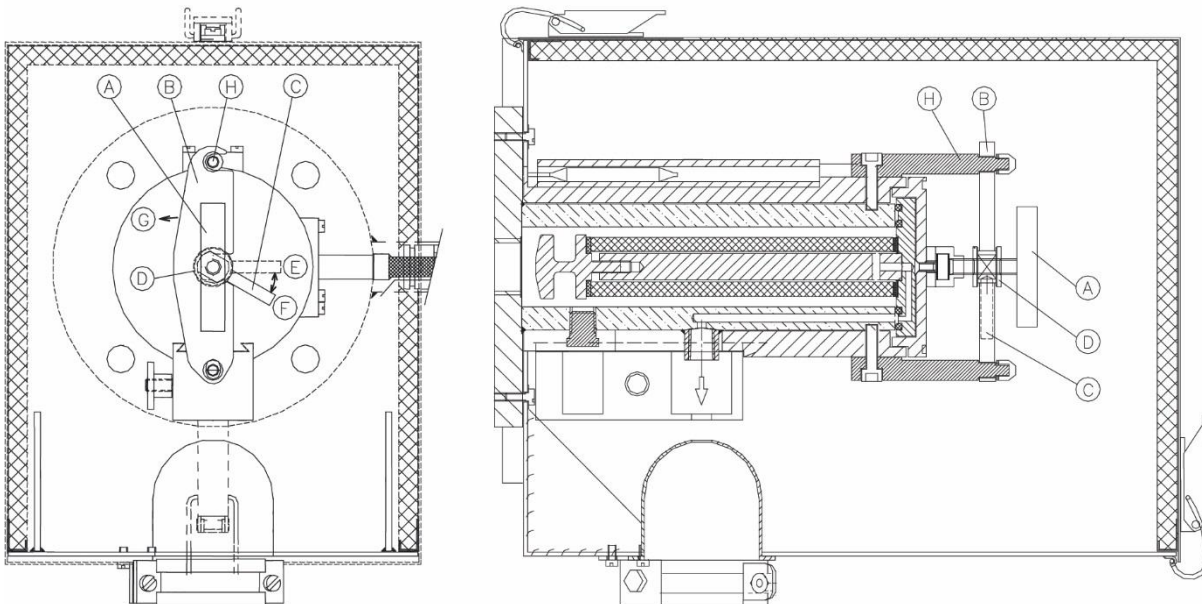

Figure 3 Cross-sectional drawing SP2000-H

- Removing the filter housing lid to check or change the filter element has to be done as follows :
- Remove the probe's protection shield after opening the two clamping devices;

- Turn toggle screw „A“ approx. 1 turn counter-clockwise, that the filter housing lid will lift up;
- Turn handle „C“ in position „E“;
- Turn clamp „B“ counter-clockwise in direction „G“;
- Take toggle screw „A“ and pull out the filter housing lid;
- Check tight fit of filter element and tighten it if necessary (hand tight) or change filter element and corresponding sealings;



WARNING!



When working during operation:

High surface temperatures!

Touching the surfaces can result in burns. Wear protective gloves and any unauthorized access to the probe must be made impossible !

- Push in the filter housing lid into the filter area;
- Turn clamp „B“ clockwise and turn with the handle „C“ the ringscrew „D“ in position „E“, that the clamp „B“ will latch into the ringscrew „D“ and the threaded bolt „H“. It could be necessary to move the filter housing lid a little bit forward and backward;
- Turn handle „C“ in position „F“ and fasten the filter housing lid by turning the toggle screw „A“ clockwise by hand.

The following pictures should explain the above mentioned steps.

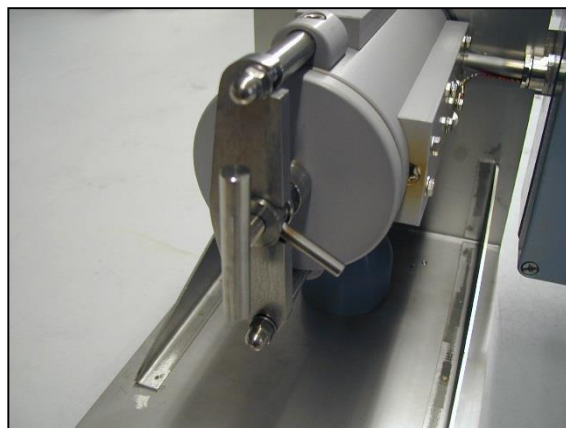
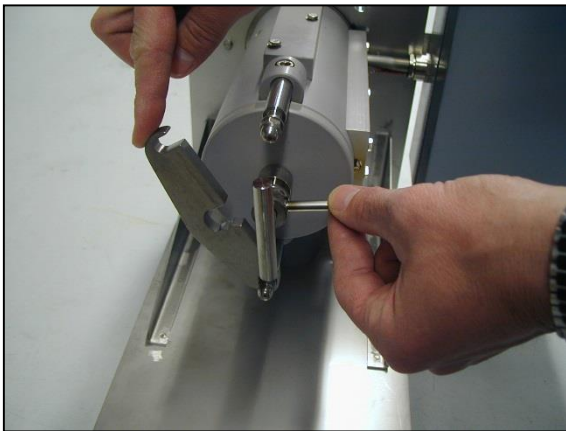

Figure 4 Removing the new filter housing lid

14.2 MOUNTING OF THE SCREWED CONNECTOR AT THE SAMPLE OUTLET

- Remove heat conducting jaws ① at the sample outlet after loosening the knurled nut ②.

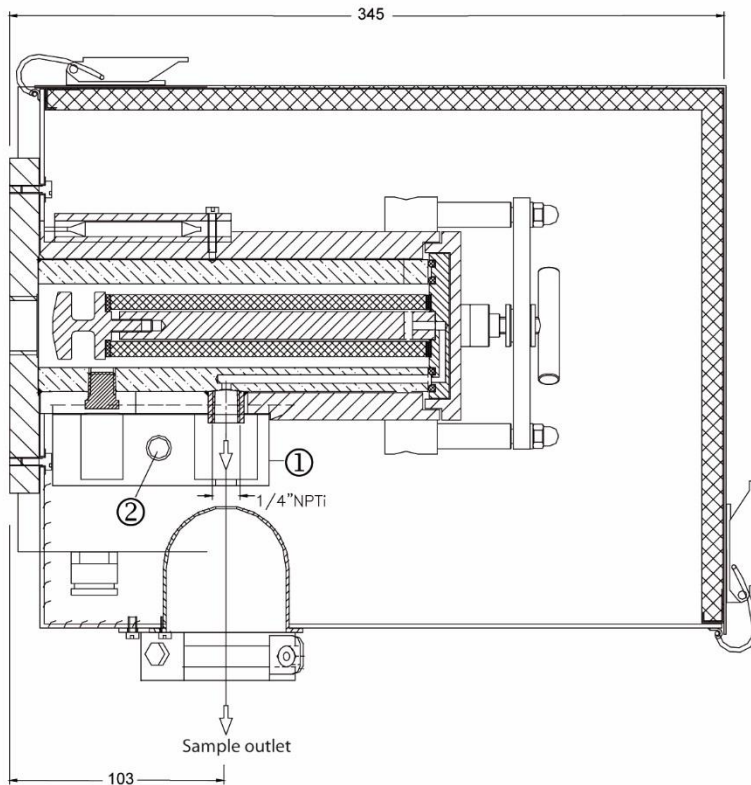

Figure 5 Mounting of screwed connector at sample outlet

- In order to connect the sample line, screw in a suitably sized threaded connector with a 1/4"-NPT connecting thread using PTFE sealing tape.
- For option second sample outlet **SP2000/2x** screw in two suitably sized threaded connectors with a 1/4"-NPTa.
- For option high heating **-H320/C** a 6mm pipe socket is welded on and a tube connector for 6mm tube connection (optional 8mm) is supplied.
- Remount heat conducting jaws and tighten knurled nut.

ATTENTION! Check tightness of the tube connections!

CARE! Never operate probe without heat conducting jaws because of the resulting cold bridge blocking of connector and line is to be expected!

14.3 MOUNTING OF PROBE WITH SAMPLE TUBE OR PREFILTER

Basically it is advantageous if the probe is built into the process with a lower downward inclination. This mounting position is absolutely necessary if the **SP32** sample tube is used for sampling e.g. after wet scrubbers, so that separated liquid drops can flow back to process.

**NOTE!**

A preferred mounting position is to have the probe with its sample gas outlet pointing downwards, although this is not absolutely necessary for perfect functioning.

- Insert flange seal ① (Fig. 6) between sampling flange and probe flange.
- If the heated probe tube type **SP30/35** or the ceramic prefilter type **V12** is used, then the probe is to be screwed to their flange ② (Fig. 6)(with welded threaded bolt). First insert the flange seal between the two flanges.
- If the probe connection does not correspond to the standard flange connection DN65 PN6, then the optionally supplied adapter flange (Fig. 2 and 6) should be mounted to the probe in the same way.
- For high pressure version **/HP** a flange ist standardmäßig ein Flansch DN50 PN25 vorhanden
- Screw either the probe tube or prefilter ③ (Fig. 6) with thread G3/4"o directly or using an extension tube ④ with the 3/4" flat gasket into the 3/4" inner thread of the flange of the probe and tighten.
- Insert sample tube or prefilter of the complete probe unit into the connection piece and screw probe at the connection piece using the screws, spring rings and nuts supplied.

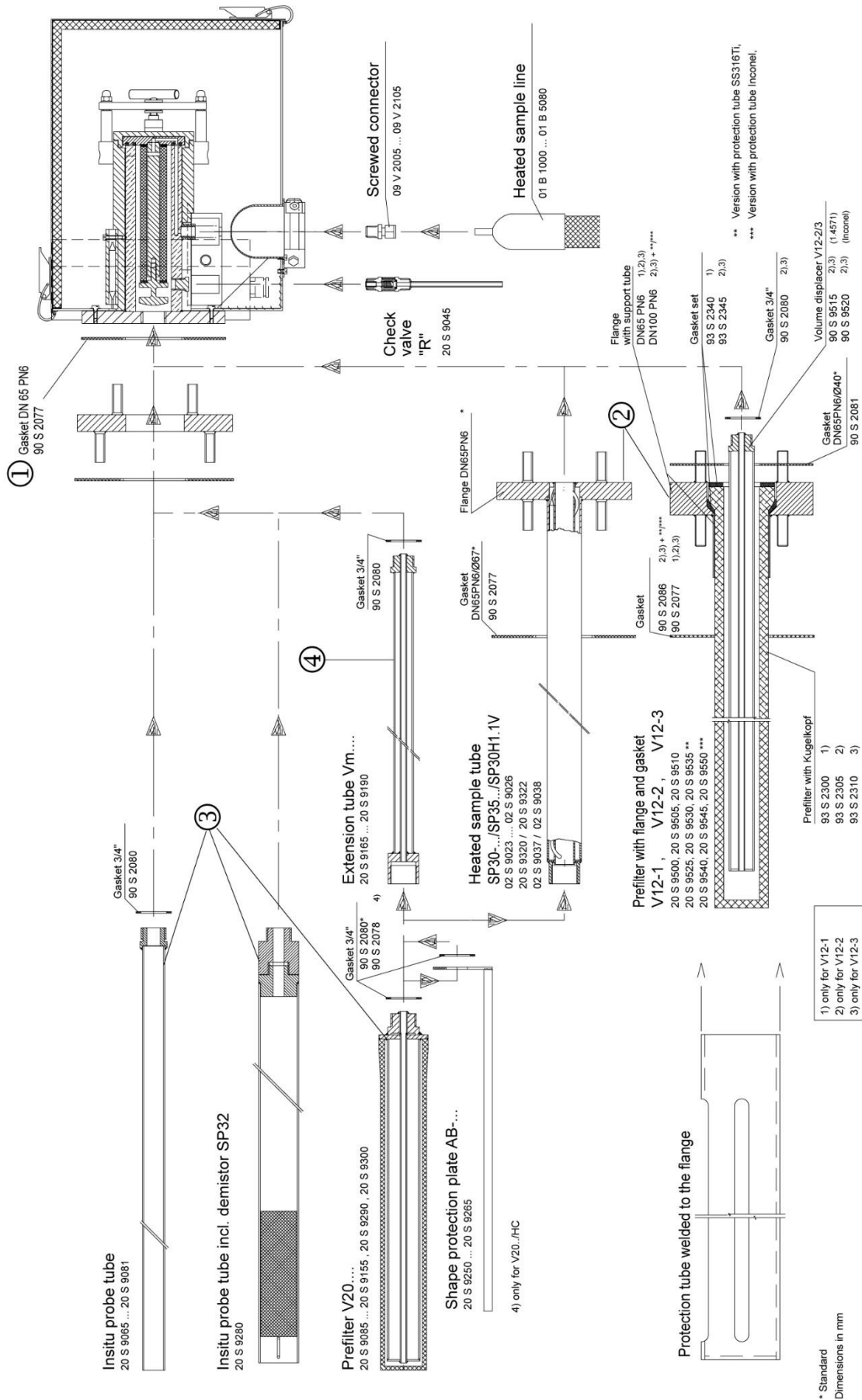

Figure 6 Mounting of sample tube or prefilter

14.4 MOUNTING OF SAMPLE LINE

- Open sample line mounting bracket ①.
- Push end of the sample line ② into silicone cap ③ in the bottom of the angle bracket.
- Depending on type of heated sample line insert stainless steel pipe end with or without PTFE line ④ through hole in the silicone cap ⑤.

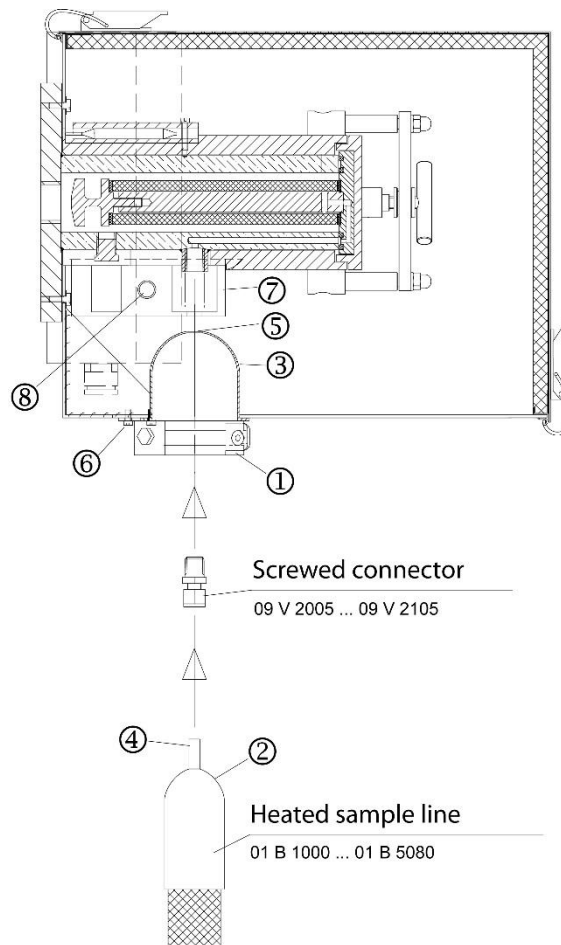

Figure 7 Mounting of heated sample line

- Connect stainless steel connection piece or interchangeable PTFE tube ④ at the fitting in the sample gas outlet of the probe. For this remove union nut with ferrule and cutting ring and put it in right order and direction on the stainless steel connection piece or the PTFE tube.

ATTENTION! If a PTFE tube is used as sample line, an insert must under all circumstances be inserted in the end of the tube in order to prevent the tube being pressed together.

- Put connection piece or tube end into the fitting in the sample gas outlet of the probe and tighten the union nut by hand.

- The temperature-resistant, stainless steel connectors supplied by **M&C** have a double ferrule system to ensure reliable sealing. After tightening the nuts of these connectors by hand, they should then be tightened exactly $1\frac{1}{4}$ of a turn using a flat spanner and are then properly mounted.
- Close mounting bracket ①. In case of larger sample line diameters, it may be necessary for the central mounting of the sample line to loosen the two screws and move the small mounting angle ⑥ of the mounting bracket and then re-tighten them.
- Now place the heat conducting jaws ⑦ around the sample gas connection in the retaining slot and fix with the knurled nut ⑧.

CARE! Never operate probe without heat conducting jaws because of the resulting cold bridge blocking of connector and line is to be expected !

14.5 CONNECTION OF OPTION TEST GAS FEEDING OR BLOW BACK LINE

- When using the options **/R** ① or 3-way ball valve option **/3VA** or **/3VA320** ②, the corresponding tubes for test gas feeding or blow back are connected by means of a tube connection on the respective 6mm tube socket ③ below the probe housing.

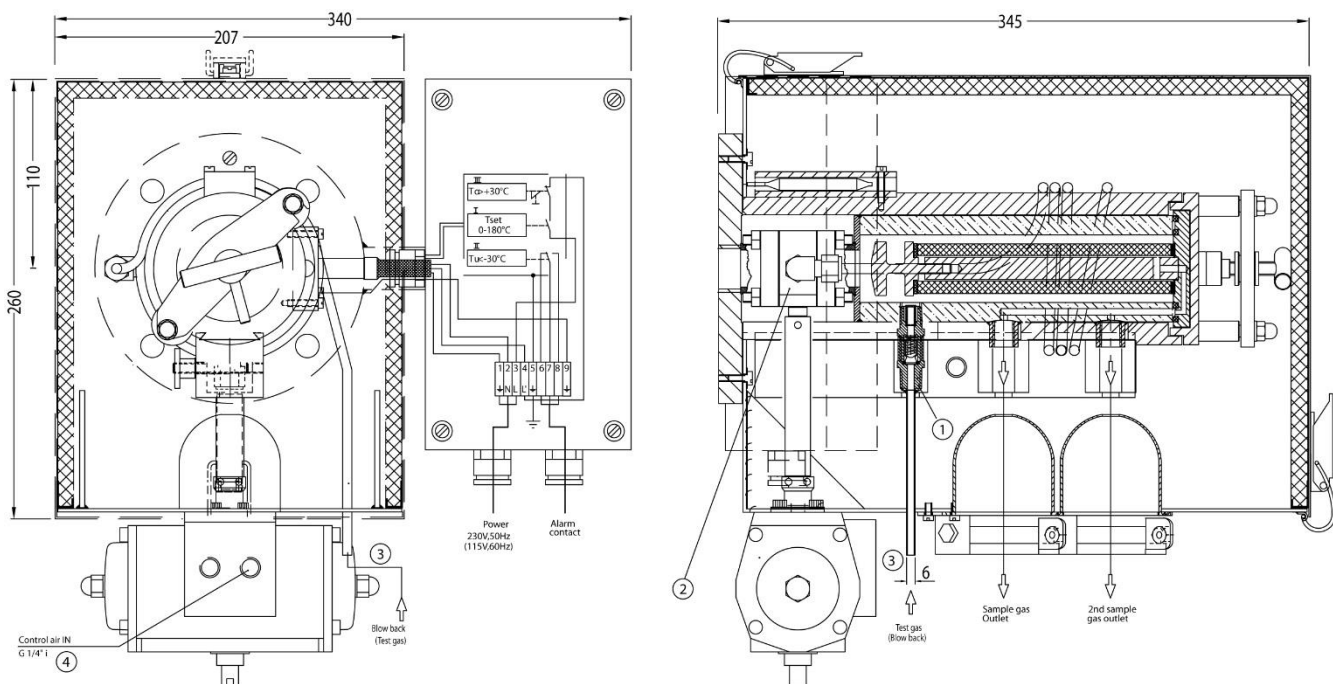

Figure 8 Connection test gas feeding or blow back line

- With option **-H320/C** it is possible to feed test gas via the standard connection for a 6mm tube that is equipped with a blind cap for the measuring operation. It is placed directly below the heat conducting jaws. For the connection of the calibration gas line, the blind cap must be removed. By means of the union nut that is attached to the consignment, the calibration gas line can be connected.

ATTENTION! After the test gas feeding being finished, the connection must be shut again with the blind cap because otherwise this connection would aspirate secondary air and falsify the measuring result !

- Optionally, the test gas feeding or back purging can be effected via a check valve **-H320/R**. The check valve is mounted in the area of the bottom plate. The connecting line (tube/pipe, 6mm outside diameter) can be connected directly on the check valve.
- After having finished the mountage, put on again the protection cap and fasten it with the quick action locks.

14.6 CONNECTION OPTION PNEUMATIC DRIVE MS1 OR MS3

The drive line for actuating the pneumatic drive is connected via a corresponding tube or pipe fitting with G1/4" outside thread ④ (figure 8 and 28 – 31). The required drive pressure is 6,5 up to 9 bar abs.

15 ELECTRICAL CONNECTIONS



WARNING!

When connecting the equipment, please ensure that the supply voltage is identical with the information provided on the model type plate.



NOTE!

Attention must be paid to the requirements of IEC 364 (DIN VDE 0100) when setting high-power electrical units with nominal voltages of up to 1000 V, together with the associated standards and stipulations.

In any case we recommend the use of temperature resistant cable !
A main switch and matching fuse must be provided externally!
The main circuit must be equipped with a fuse corresponding to the nominal current (over current protection); for electrical details see technical data.

It is recommended to use the low temperature alarm. In case of an alarm the flow can be stopped and the components downstream the probe are safe for damage.

15.1 STANDARD VERSION WITH INTERNAL CAPILLARY TUBE THERMOSTAT

- Remove the lid of the connection box. The electrical connection layout is also located in the lid (Fig. 9).
- Insert the mains cable (min. 3 x 1.5 mm², clamping range 6-12mm) through the left cable gland M20x1,5 and connect to the appropriate terminals.
- Insert the signal cable through the right cable gland and connect to the appropriate terminals.
- Screw lid back on.

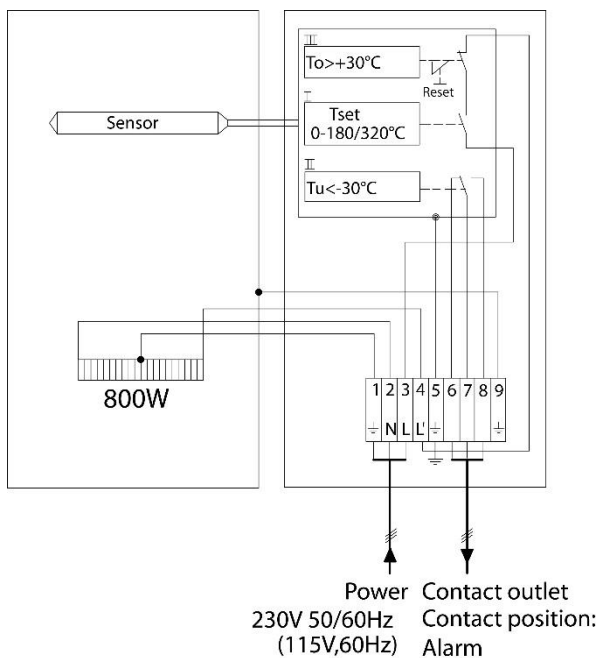

Figure 9 Electrical connection for SP2000-H, SP2300-H and SP2400-H with thermostat controller

15.2 VERSION WITH PT100 OR THERMOCOUPLE (OPTION)

In case the gas sample probe is ordered with temperature sensor instead of the thermostat, an electronic temperature regulator is necessary, such as the **M&C** regulator **70304G** (Part No. 01B8451). This instrument can be delivered already mounted on the probe and electrically connected, or it is attached to the consignment as separate unit for external moutage. Then it has to be electrically connected as follows:

- Remove the lid of the connection box. The electrical connection layout is also located in the lid (Fig 10).
- Insert the mains cable coming from the external temperature controller (min. 3 x 1.5 mm², clamping range 6-12mm) through the left cable gland M20x1,5 of the connection box and connect to the appropriate terminals.
- Insert the temperature sensor cable through the right cable gland M20x1,5 and connect to the appropriate terminals.
- Screw lid back on.



NOTE!

In case of versions with thermoelement (e.g. with option -H320/C) a compensation wire is to be provided as sensor line. Corresponding balancing terminals are provided in the connection box.

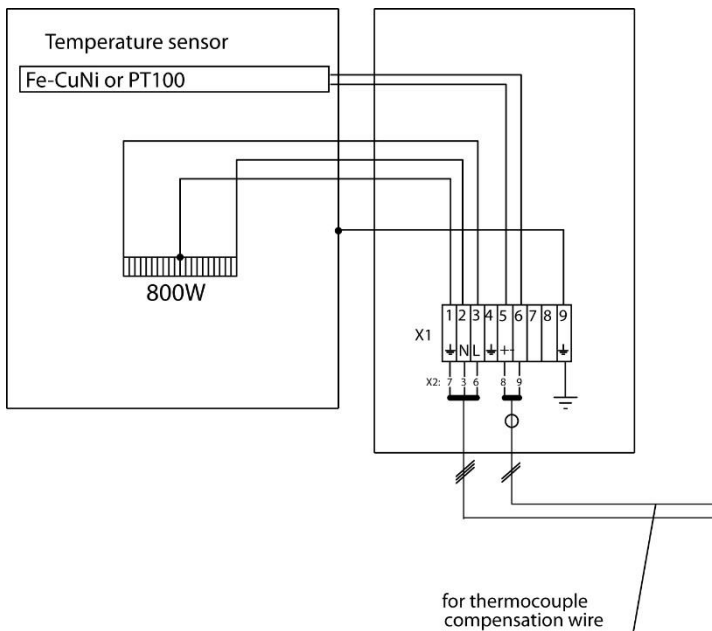

Figure 10 Electrical connection of external temperature controller e.g. 70304G

The electrical connection of the temperature regulator **70304G** is effected according to the connection plan (figure 11) and as described in the following:

- Unscrew and remove the housing lid.
- Introduce the mains cable (min. 3 x 1,5 mm², clamping range 6-12mm) through the left cable gland M20x1,5 of the regulator and connect it to the respective terminals.
- Introduce the cable for the alarm contact (clamping range 6-12mm) through the right cable gland M20x1,5 and connect it to the respective terminals.

In case the temperature regulator **70304G** is attached as separate unit, the probe has additionally to be connected with the regulator, according to figure 10 and the following description:

- Introduce the power cable for the sample gas probe (min. 3 x 1,5 mm², clamping range 6-12mm) through the second cable gland M20x1,5 of the regulator and connect it to the respective terminals.
- Introduce the temperature sensor cable (clamping range 6-12mm) through the third cable gland M20x1,5 of the regulator and connect it to the respective terminals.
- Screw the lid on the housing again.

CARE !

If not all cable glands are used for the electrical connection of the temperature regulator, the remaining ones must be shut in order to guarantee the tightness of the housing.

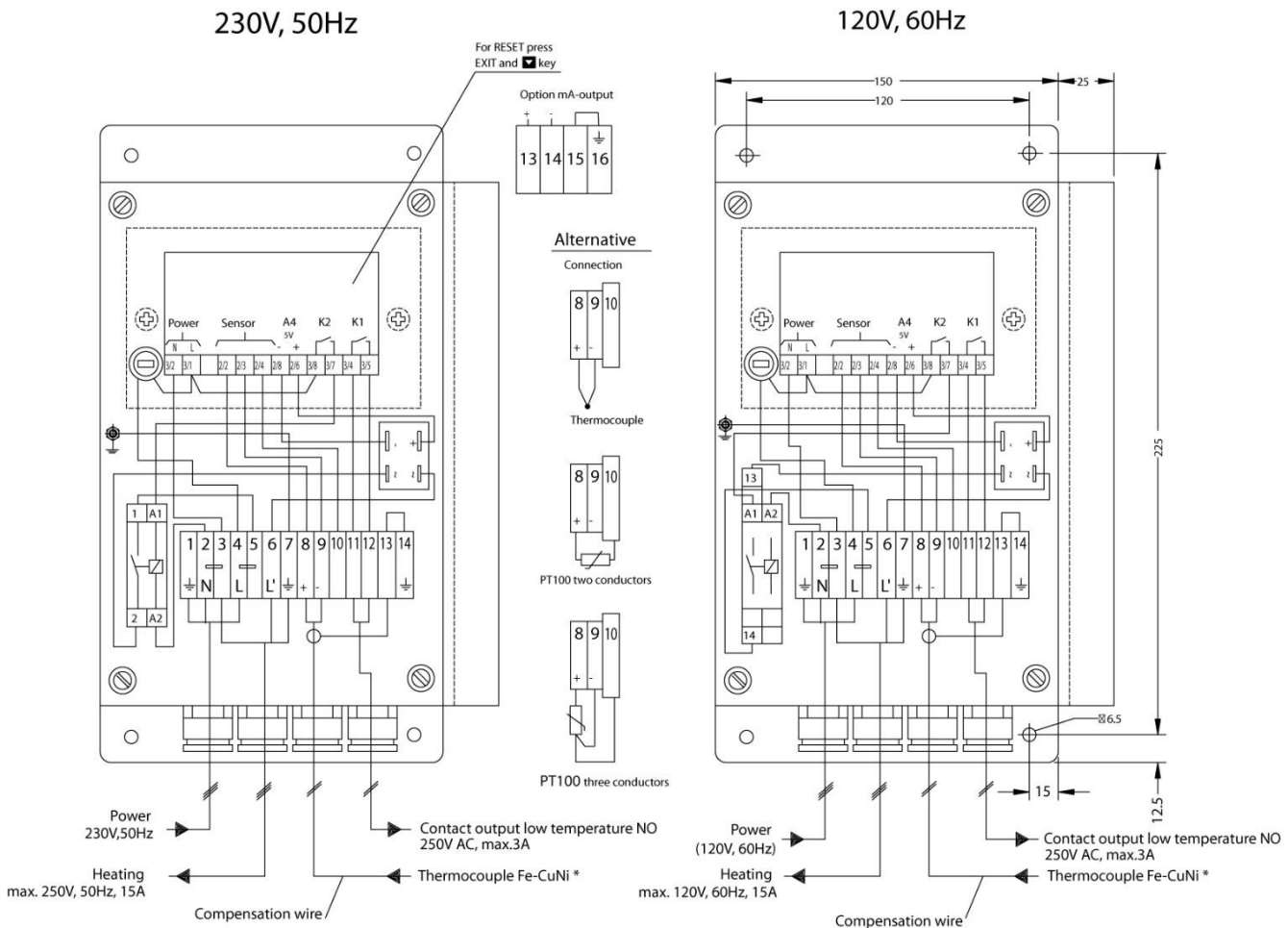

Figure 11 Electrical connection electronic controller 70304G

16 STARTING

- Before starting up check whether the mains power supply voltage corresponds with the information stated on the probe's nameplate.
- If there is a built-in ball valve you should also check, if it is closed. In case of hand-operated ball valves, the control grip must be located at the right-hand stop.
- Switch on mains power supply.
- Check the rated value setting on the built-in thermostat or on the external controller.
- The total heating-up time is approximately 2 hours. After about 1 hour the probe is already sufficiently heated for the temperature to have exceeded the temperature failure alarm value (30°C below rated value), but it still takes about another hour until operating temperature is reached.
- If a ball valve is fitted, operate this via the pneumatic drive or for a 2/2-way ball valve by turning the control grip by hand up to the left-hand stop and for a 3/2-way ball valve into mid position.
- The probe is ready for operation now.

**NOTE!**

If the rated value temperature needs to be lowered more than 28°C in one step during operation, the thermostat's excess temperature switch-off is triggered!

**WARNING!**

When working during operation:

High surface temperatures!

Touching the surfaces can result in burns. Wear protective gloves and any unauthorized access to the probe must be made impossible!



16.1 GAS SAMPLE PROBE SP2300-H

At the gas sample probe **SP2300-H** exists the electrical heated filter body from carbon filled PTFE. When heating up the probe, conditionally through the different linear expansion between PTFE and the heater body manufactured from aluminium, the extension of the PTFE-part is larger than the Aluminium part.

**NOTE!**

We recommend therefore, to loosen the locking screw in the clamp, at the first heating up, to relieve the O - rings in the cover, or better remove the complete filter housing lid.

After reaching the operating temperature (>2 hours) insert the complete filter housing lid in the probe, and press the clamp by turning the locking screw.

16.2 OPTION CALIBRATION GAS FEEDING AND BLOW BACK

16.2.1 OPTION CHECK VALVE /R

In order to backflush the probe tube or the prefilter, flush gas is fed via the backflush valve **/R**. It is advisable to disconnect the downstream analysis system from the probe before doing this in order to avoid pressure shocks on the system. The check valve's opening pressure is 0,7bar.

**NOTE!**

In order to prevent the probe's interior from cooling down, back-flushing should as far as possible only be carried out for short intervals <1s or use a gas pre-heater type GVW.. (see data sheet 2-1.2.5).

**NOTE!**

Feed the back purge gas as quick as possible and with a big nominal width in order to avoid a loss of pressure in the feeding line during the back purge action.

- The analysis system remains closed while calibration gas is being fed.
- The amount of calibration gas should be at least 25% greater than the amount of sample gas drawn into the analysis system in order to avoid mixing with the sample gas.

- This type of calibration gas feeding is not to be used in case of processes with over pressure. A built-in ball valve in the probe entrance is recommended here. Basically, a smaller amount of calibration gas is needed in probes with built-in ball valve as the probe is separated from the system on activating the ball valve and thus there is no danger of mixing with the process gas.
- In order to close the probe the control grip has to be turned by hand to the right up to the stop.



In case of vacuum care should be taken that no infiltrated air is drawn in via the unclosed non-return valve from 300 mbar upwards.

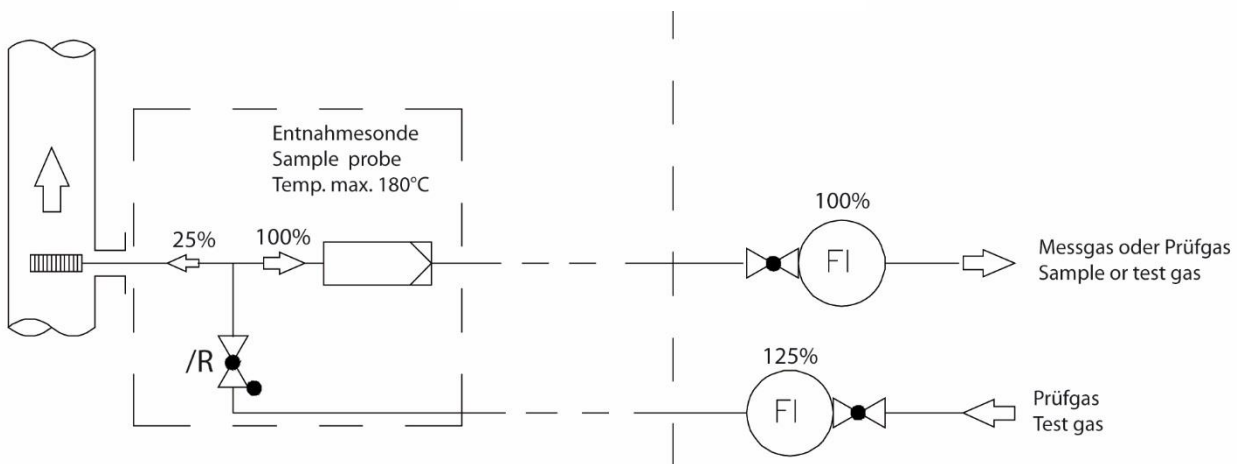

When feeding calibration gas via check valve /R at the probe, mixing with sample gas must be avoided. The calibration gas flow should be at least 25% higher than the flow of sample gas.

Figure 12 Calibration gas feeding

16.2.2 VIA 3/2 WAY BALL VALVE /3VA

With the 3/2 way ball-valve the two functions "backflush and calibration gas feed" can be carried out one after the other. Only one function can be automated via the pneumatic drive.

This method of gas feed has the advantage that during backflushing the downstream analysis system is automatically separated from the probe and during calibration gas feed, the probe is automatically separated from the process and therefore a smaller amount of calibration gas is needed as no mixing with the process gas can occur. During function blow back it is possible to feed test gas via an additional check valve /R at the same time (see also Fig. 13).

- For sampling operation turn handle to mid position.
- For blow back turn handle from mid to left position up to stop.
- For test gas feeding turn handle from mid to right position up to stop.
- For measuring operation turn handle back to mid position.

16.3 OPTION BALL VALVE DRIVES

For external control of the probe internal ball valves there is the possibility to use a pneumatic drive with return spring type **MS1**, **MS3** (for 320°C) or an electric drive **EA**.

16.3.1 OPTION PNEUMATIC DRIVE MS1 OR MS3 WHEN USING A 2/2-WAY BALL VALVE /VA

Ball valve open = measuring operation

Ball valve closed = e.g. changing filter element at process excess pressure or toxic sample gas or test gas feeding with option check valve **/R** without loss of test gas into the process.

Gasentnahmesonde / Sample probe
SP2000-H/R/VA/MS1-NC (NO)

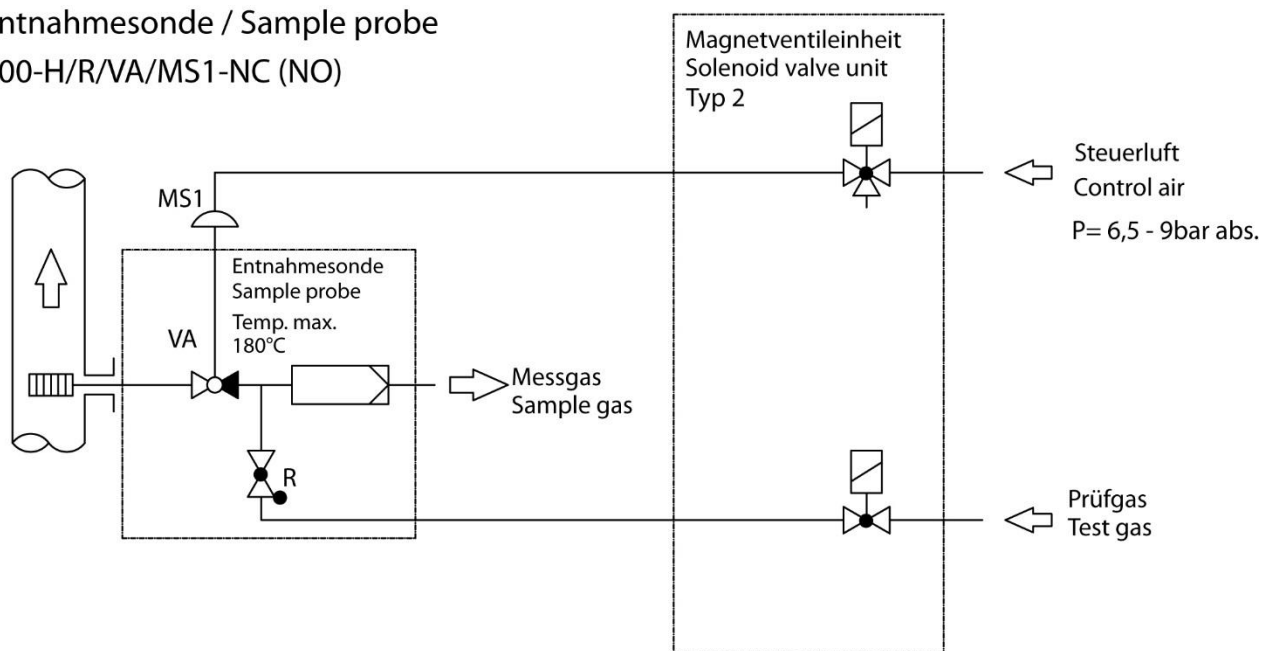

Figure 13 Pneumatic drive for 2/2-way ball valve

When placing the order it shall be specified whether the ball valve should be

NC, without control air closed, or

NO, without control air open and hence switched to measuring.

Standard = **NC**

16.3.2 OPTION PNEUMATIC DRIVE MS1 OR MS3 WHEN USING A 3/2-WAY BALL VALVE /3VA

1. Measuring and blow back **MS-B**
2. Measuring and test gas feeding **MS-C**

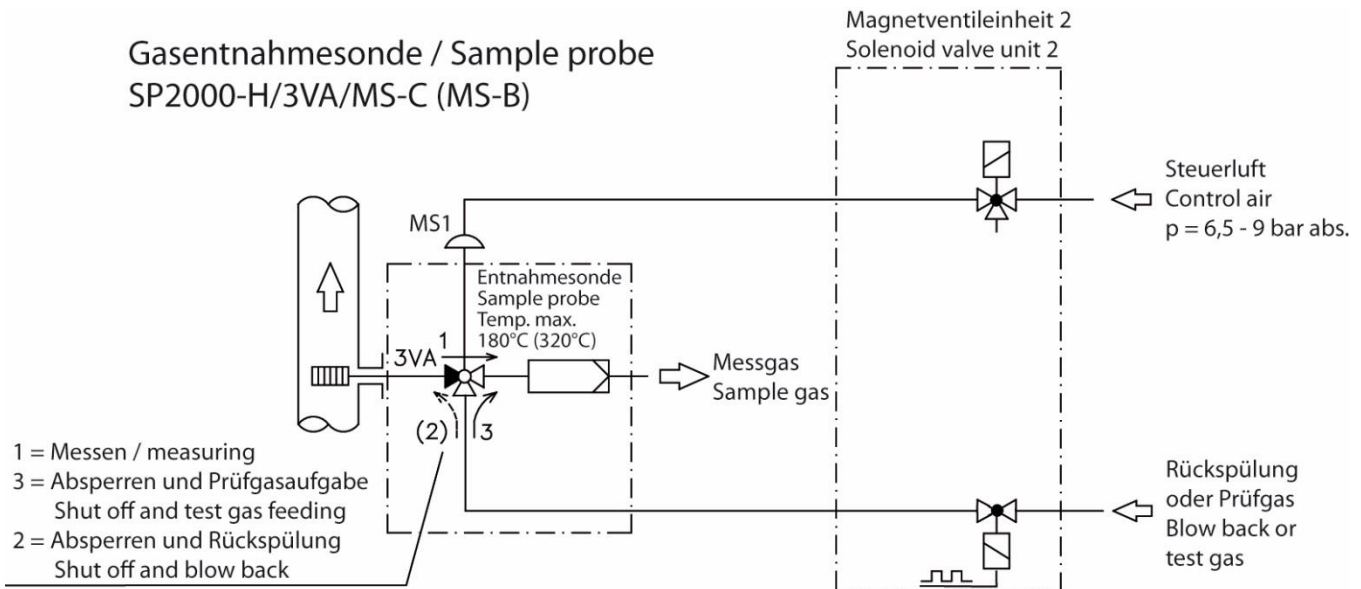

Figure 14 Pneumatischer Antrieb für 3/2-Wege Kugelhahn

When placing the order it shall be specified whether the ball valve should be

NC, without control air closed resp. switched to test gas feeding or blow back, or
NO, without control air open and hence switched to measuring.

Standard = **NC**

16.3.3 OPTION ELECTRICAL BALL VALVE DRIVE

The electrical ball valve drives for control of two operating modes are available in three control voltages 230V, 115V or 24V DC.

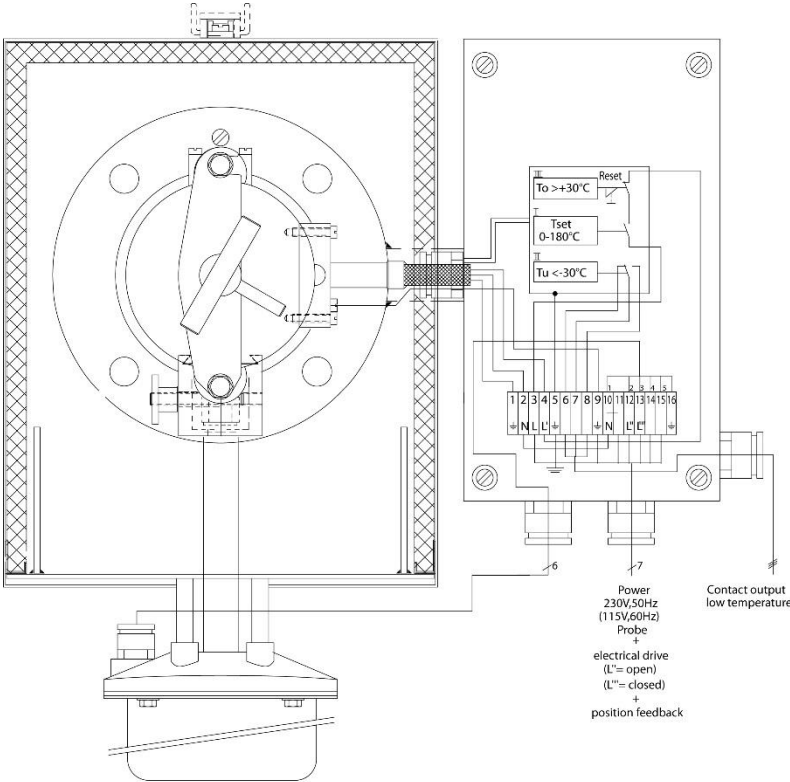

Figure 15 Electrical connection for electrical ball valve drive

16.4 OPTION SOLENOID VALVE UNITS FOR BLOW BACK, TEST GAS FEEDING AND CONTROL OF THE PNEUMATIC DRIVES

All solenoid valve units contain a 3/2-way solenoid valve for control of the pneumatic drive. One way of the solenoid valve is used for switching the ball valve the other for ventilation and hence resetting the ball valve. Furthermore depending on demand 2/2-way solenoid valves for blow back and/or test gas feeding are existing.



NOTE!

Feed the back purge gas with a nominal width as big as possible in order to avoid losses of pressure in the feeding line during the back purge action.

The following solenoid valve units are for example available:

Solenoid valve unit 2

With 2 solenoid valves for control of 2 operating conditions:

1 x 3/2-way solenoid valve for switching from measurement operation to back purging **or** feeding of test gas.

1 x 2/2-way solenoid valve for feeding of test gas or back purge gas

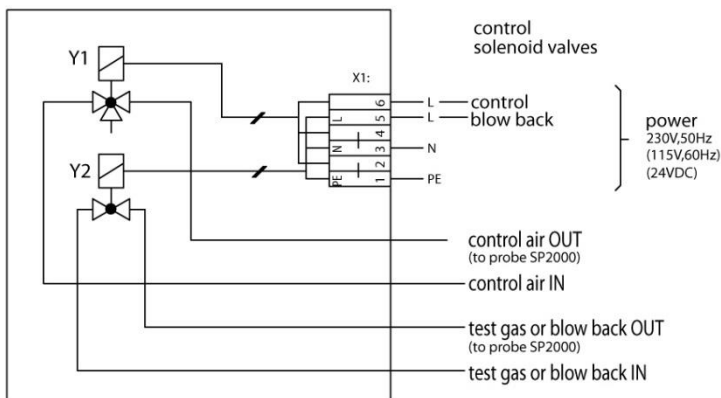
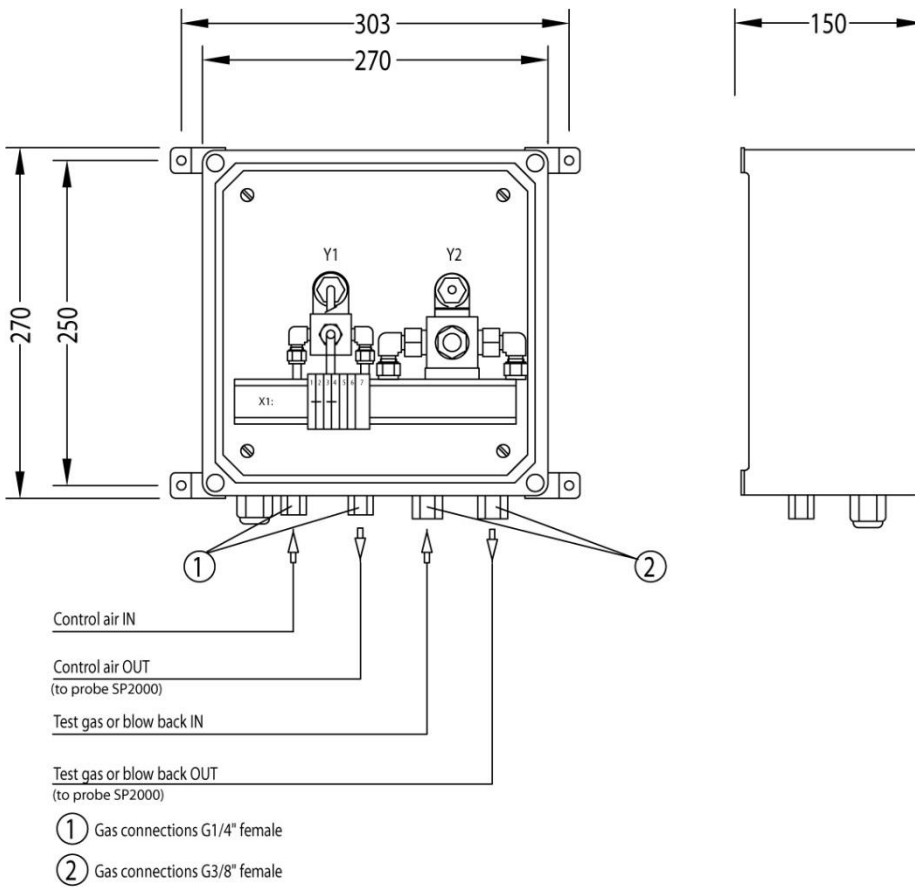

Figure 16 Connections solenoid valve unit 2

Solenoid valve unit 3

With 3 solenoid valves for control of 2 operating conditions:

1 x 3/2-way solenoid valve for switching over from measuring operation to back purging for eg. option /3VA

1 x 2/2-way solenoid valve for feeding of test gas via option /R

1 x 2/2-way solenoid valve for feeding of back purge gas

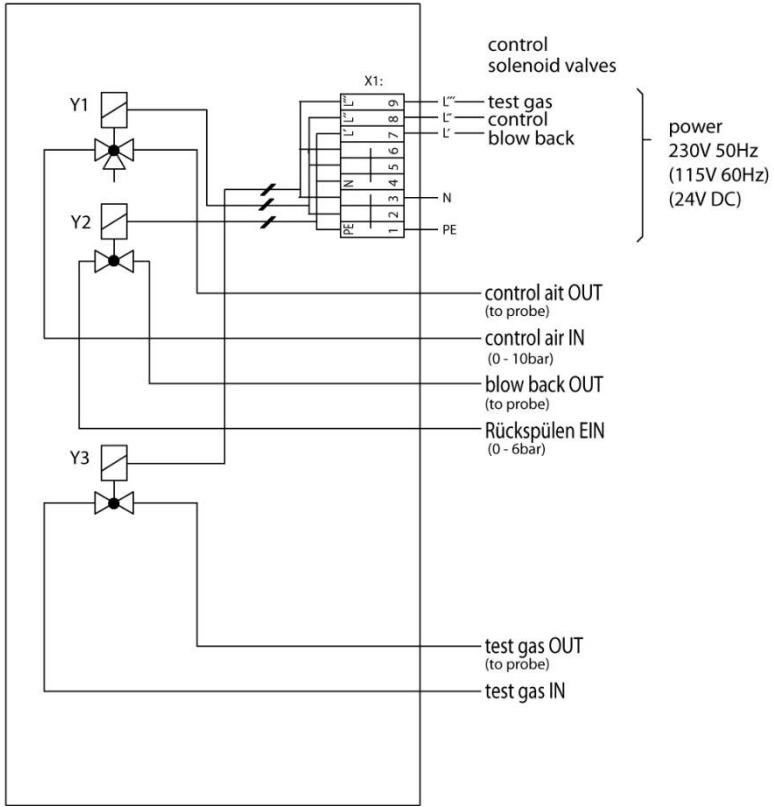
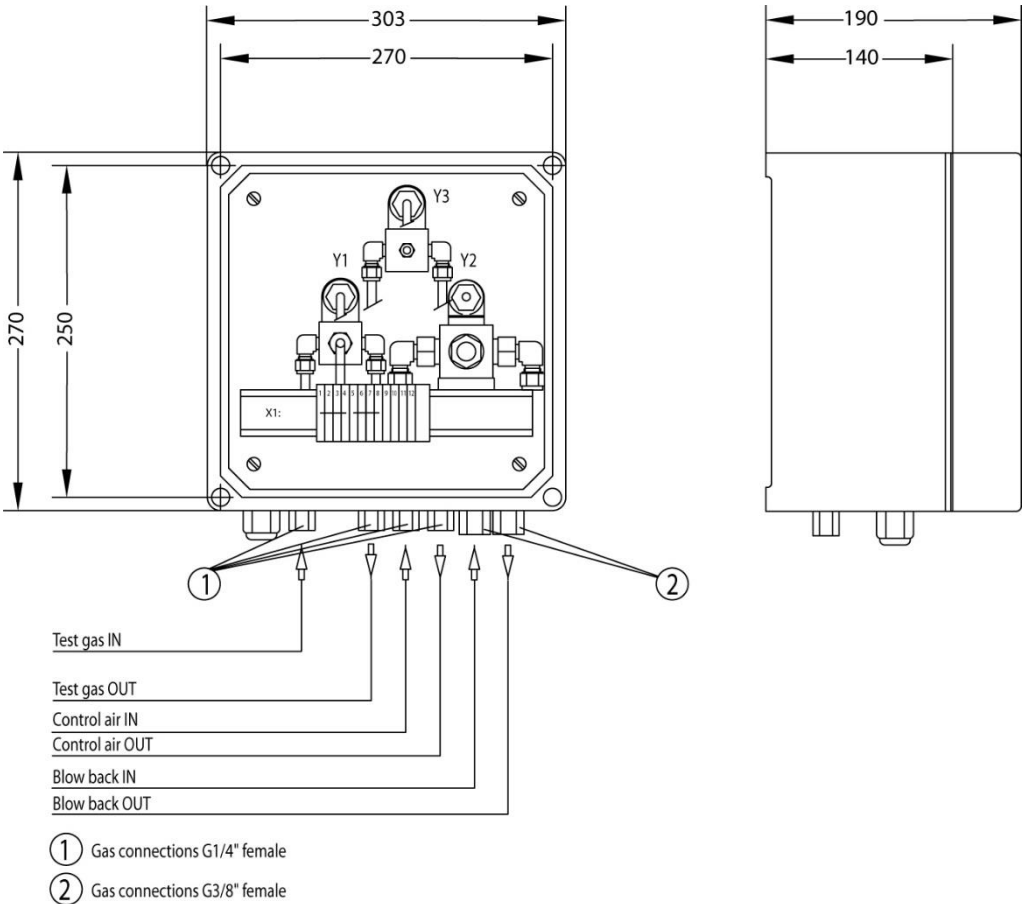

Figure 17 Connections solenoid valve unit 3

16.4.1 OPTION DRIVE UNIT 234B FOR THE SOLENOID VALVE UNITS

The drive unit **234B** is used for control of the solenoid valves in the solenoid valve units for a clocked back purging. The unit is mounted on a cap rail inside a GFK protection housing of the solenoid valve unit and is delivered electrically connected.

16.4.1.1 Function and adjustment of the clock generator K3



The control of the back purge action is made via the electronic clock generator **K3** (Typ CT-MXS.22) that is equipped with 2 separate time adjustment possibilities for the impulse and the pause duration. During the impulse duration, the probe is pack purged.

In the front of the clock generator are situated the adjustment possibilities for the time ranges (Range) and the potentiometer for the fine adjustment (Time). Thus, any back purge and pause durations can be separately adjusted. For the fine adjustment (Time) the scale is valid which corresponds to the colour of the time range adjustment (Range).

Example:

The back purging shall be effected every 12 hours for totally 10 seconds.

Duration of the back purging: 10s

Pause: 12 h

Adjustment „Duration of the back purging“ (10s): Set the potentiometer (Time 2) to 10 (white scale) and the time range (Range 2) to 10s.

Adjustment „Pause“ (12h): Set the time range (Range 1) to 30h and the potentiometer (Time 1) to 12 (orange scale).

16.4.1.2 Function and adjustment of the clock generator K2

Via the clock generator **K2** (EZ12TI), the solenoid valve **Y2** (figure 15 and 16) for the feeding of back purge gas is controlled. Here, you can adjust the lengths of the back purge impulses and the pause durations between the pack purge impulses.



In the front of the clock generator **K2** the switch for the time basis T and the multiplier xT1 and xT2 is situated. The duration of the back purging, eg. 1s is set with xT1 and the duration of the pause between the back purge blows is set with xT2, eg 1s.

Example:

Clock time and pause duration: 1s

Adjust the time basis T at 0,5s and the multiplier xT1 and xT2 at 2.

(2 x 0,5s = 1s)

16.4.1.3 Function and adjustment of the time delay relay K1



After the back purge action, the time relay **K1** (EZ12AV) finishes the message „Back purge“ with a time delay of eg. 1min and releases the measurement again in order to have sample gas in the analysers when you switch over from back purging to measuring.

In the front of the time relay, the switches for the time basis T and the multiplier xT are situated.

Example:

Delay time: 1min.

Adjust the time basis T to 1 min. and the multiplier xT to 1 (1 x 1min. = 1min).

16.4.1.4 Function for ball valve position NC „normally closed“

After actuation of the back purge action by **K3** (type CT-MXS.22), the message purging is given via the time relay **K1** (EZ12AV), the control solenoid valve **Y1** (see figure 15 and 16) is closed and the ball valve returns in its rest position by spring return (back purge).

The clock relay **K2** (type EZ12TI) is piloted for eg. 10s and switches on and off again the back purge solenoid valve **Y2** in a clock cycle of eg. 1s.

After this, it is pause time in which the solenoid valve **Y1** is changed over again to the measuring gas sampling. At the same time, the time-delay relay is switched which – after a delay time of eg. 1 min. - finishes the message „purging“ and releases again the measurement. This delay time is necessary in order to have active sample gas in the analysers during switching over from purging to measuring.

16.4.1.5 Function for ball valve position NO „normally open“

After actuating the back purge action through **K3** (type CT-MXS.22), the message „purging“ appears via the time relay **K1** (EZ12.AV), the control solenoid valve **Y1** (see figure 15 and 16) is opened and the pneumatic drive moves the ball valve into position „back purging“.

The clock relay **K2** (type EZ12.TI) is piloted for eg. 10s by **K3** and switches on and off again the back purge solenoid valve **Y2** in a clock cycle of eg. 1s.

After this, it is pause time in which the solenoid valve **Y1** is changed over again to the measuring gas sampling. At the same time, the time-delay relay is switched which – after a delay time of eg. 1min. – finishes the message „purging“ and releases again the measurement. This delay time is necessary in order to have active sample gas in the analysers during switching over from purging to measuring.

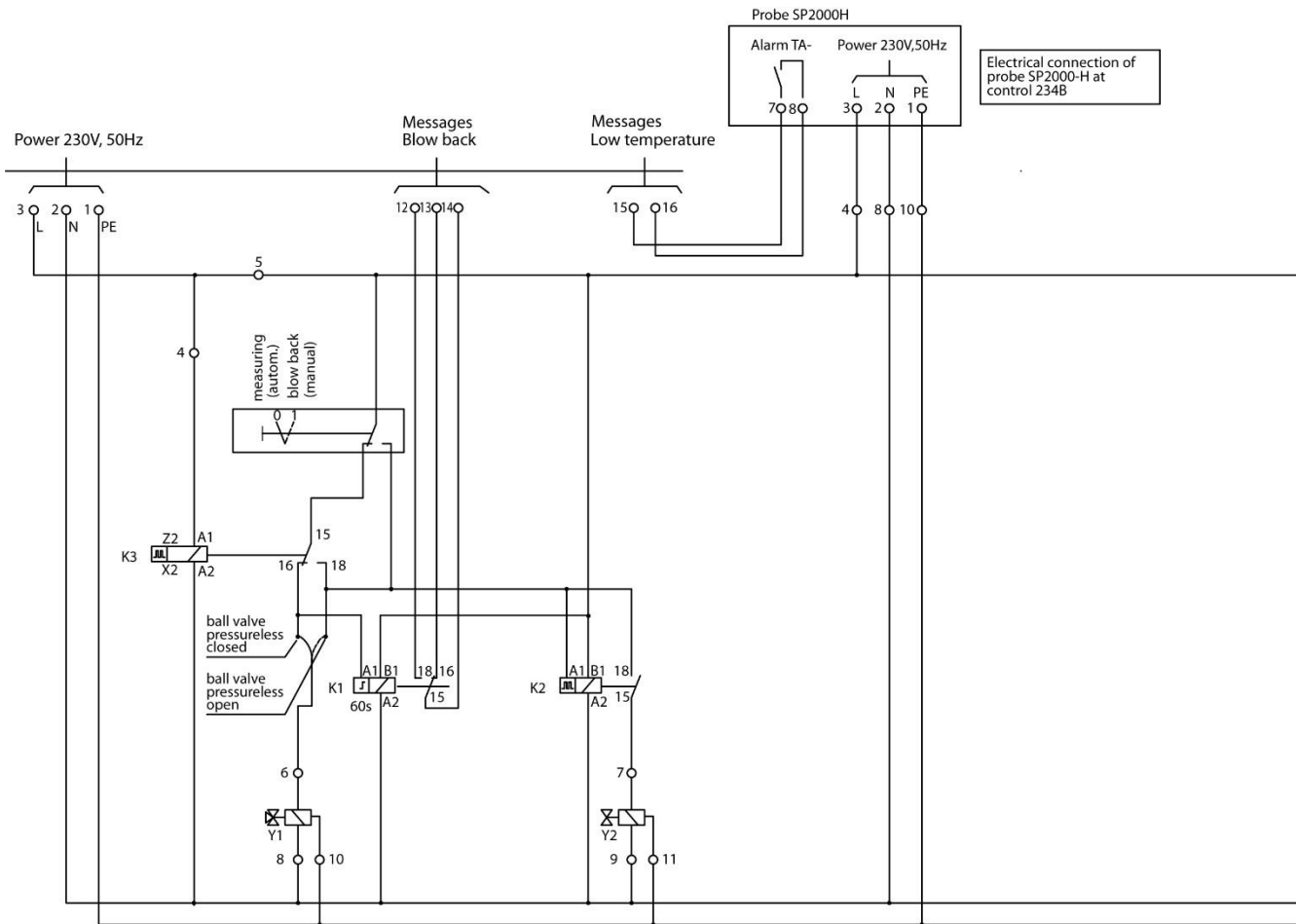

Figure 18 Wiring plan of control unit 234B

17 MAINTENANCE

The safety instructions specific to the plant and process are to be consulted prior to any maintenance work !

It is difficult to give any recommendations as to a particular maintenance cycle. Depending on your process conditions, a meaningful maintenance cycle must be elaborated for the specific application. An indication that probe-maintenance may be necessary could be shown by a constant decline in the amount of sample gas in the analysis system.

Probe maintenance is restricted essentially to replacing filter elements and checking seals.



WARNING!

Observe safety related operations specific guidelines for maintenance work !



WARNING!

**Aggressive condensate is possible.
Wear protective glasses and proper protective clothing!**



WARNING!

**When working during operation:
High surface temperatures!
Touching the surfaces can result in burns. Wear protective gloves
and any unauthorized access to the probe must be made impossible
!**



17.1 CHANGING FILTER ELEMENT AND CHECKING SEALINGS

- Close ball valve (if fitted). **Flush probe in case of toxic gases!**
- Remove probe protection shield after opening pressure clamps.
- Remove filter holder with lid as described in chapter 14.1.
- Screw out the filter's knurled screw **I**, if existing put adapter **L** into the new filter element and renew filter element **J**.
- Check filter element seals **K** and replace if necessary.
- Check O-rings in the lid (flat graphite seal for **/320H...**, PTFE rings for **/7aT**) and change if necessary.

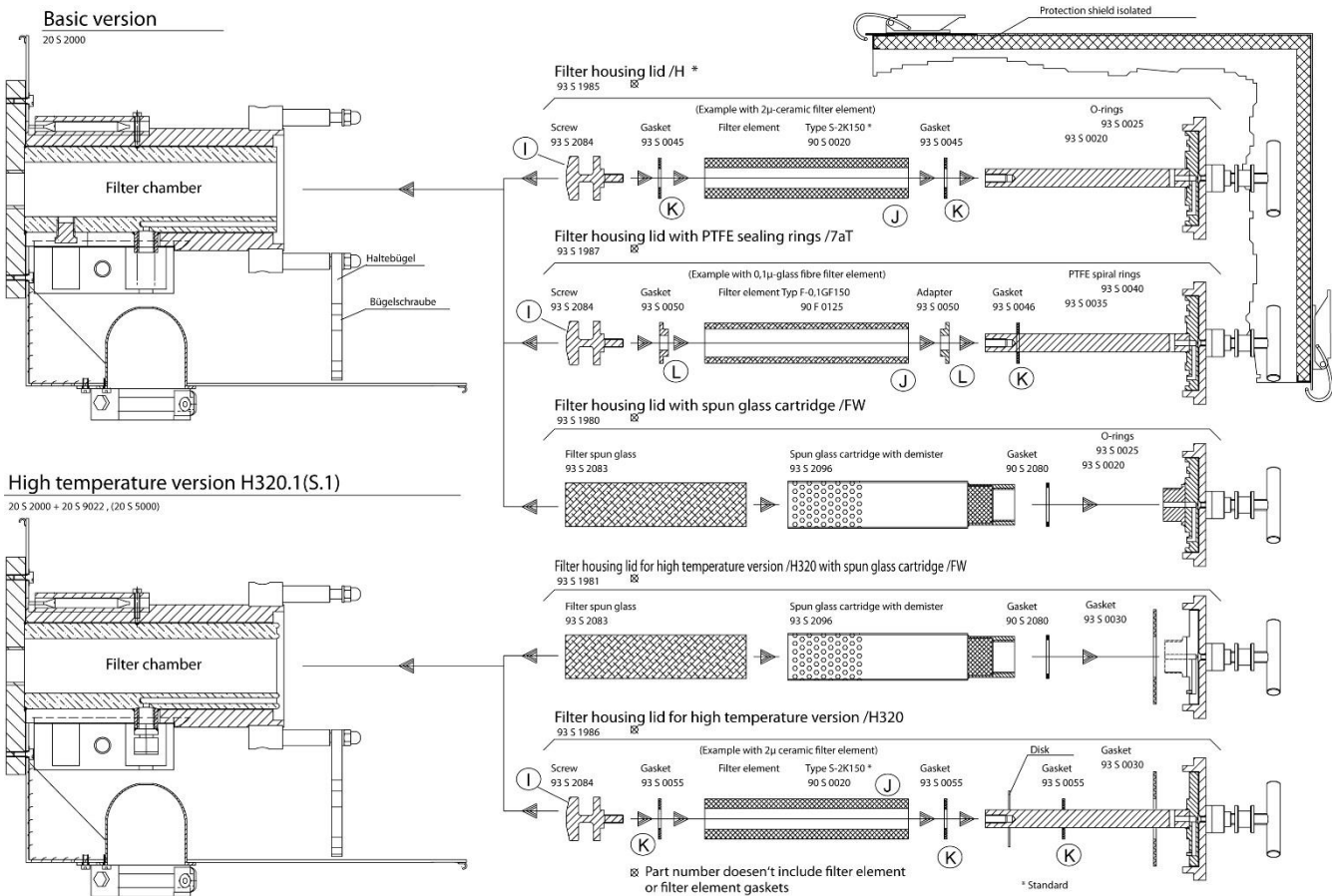

Figure 19 Filter elements and gaskets

- Clean filter chamber.
- It is now also possible to rod through the probe tube in order to remove deposits. Take care to avoid breakages when handling probe tubes made of alu-oxide !
- Replace filter holder with lid, turn handle **C** into position **E** and tighten lid with toggle **A** again.
- Replace protection shield.
- Open (if available) ball valve.

In order to change prefilters, the entire probe unit must be removed from the process. The prefilters can be cleaned to an extent depending on the manner of soiling mechanically or in a ultra sonic bath and can be used again.



**Prior to carrying out maintenance work on electrical parts, mains voltage should be disconnected from all poles!
This also applies to any external control circuits which may be connected.**

17.2 CHANGE OF THE OPTIONAL PREFILTER

For changing the prefilter the complete probe unit has to be dismantled and removed out of the process :



WARNING!



When working during operation:

High surface temperatures!

Touching the surfaces can result in burns. Wear protective gloves and any unauthorized access to the probe must be made impossible !

- Loosen the 4 flange nuts and remove if possible the fixing screws (not for prefilters V12..., adapter flanges or SP30-H....)
- Extract probe with prefilter out of the process.
- Let prefilters cool and than screw out resp. for prefilters V12... remove the 4 flange nuts on probe side (see also Fig. 6).
- Change or clean prefilter.



NOTE!

Prefilters depending on type and degree of contamination can be partly cleaned mechanically or in an ultra sonic bath and reused.

17.3 CHANGE OF HEATING CARTRIDGE AND THERMOSTAT



WARNING!



Before effecting any maintenance work, the mains voltage has to be switched off on all poles! This is also valid for eventually connected alarm or control circuits.

- Switch the probe free of tension (switch off the mains voltage) and let it cool down.
- Open the toggle type fasteners and take off the protection cover.
- Take off the lid of the electrical connection box after having unfastened the 4 screws.

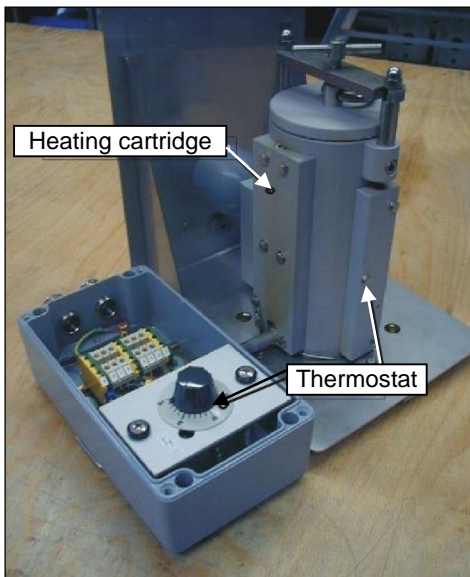

Figure 20 Position of Thermostat and heating cartridge

- Unscrew the two hexagon head cap screws **A** (figure 21) in the back board of the connection box with which this one is mounted to the retaining plate.

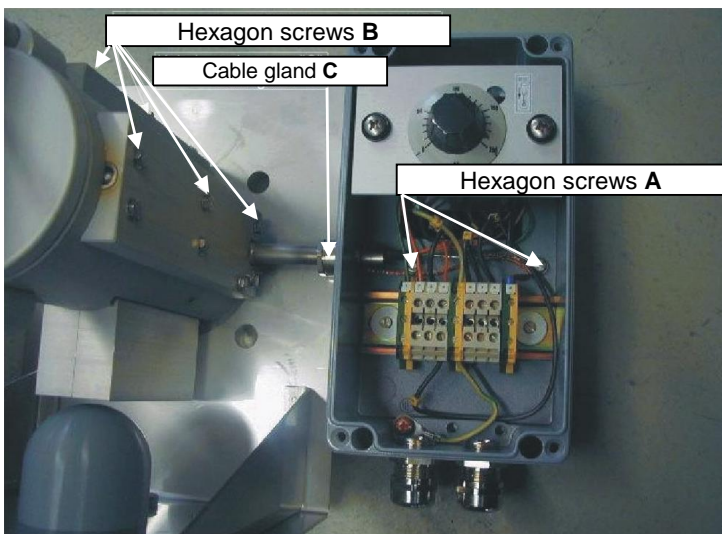

Figure 21 Position of fixing screws of connection box, thermostat sensor and heating cartridge carrier plate

- Unscrew the hexagon head cap screws **B** (figure 21) for the fastening of the heating cartridge retaining plate and the thermostat sensor retaining plate.
- Remove the connection box including the heater cartridge and the thermostat sensor.

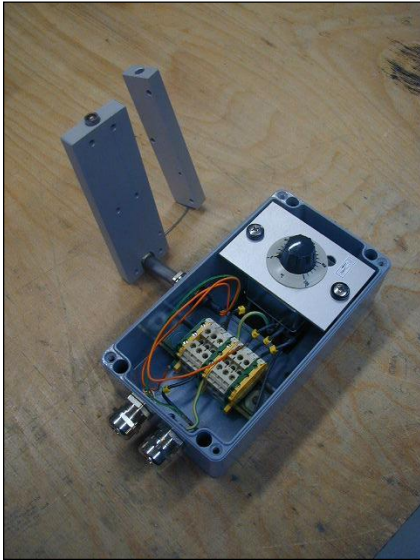

Figure 22 Dismounted electrical connection box with heating cartridge and thermostat sensor

- Loosen the cable gland **C** (figure 21) for the heating cartridge and the capillary tubes of the thermostat.
- Disconnect the electrical connection lines of the heating cartridge and the thermostat from the terminal block (figure 9).
- Take off the turning knob from the thermostat. Remove the 2 locking screws **D** (figure 23) beneath. Take off the locking screws **E** (figure 23) of the thermostat retaining plate.
- Draw the heating cartridge through the cable gland **C** (figure 21) out of the connection box.
- Draw out the thermostat sensor through the cable gland in the opposite direction.
- Mount the new thermostat and lead the thermostat sensor from inside through the cable gland.
- Feed the new heating cartridge from outside through the cable gland.
- Connect the electrical cables according to the connection plan (figure 9).
- Mount the complete unit to the probe again.

The thermostat is equipped with a mechanical stop that limits the maximum temperature adjustable via the turning knob.

When mounting the thermostat pay attention that the mechanical stop is mounted so that the arrow on the metallic ring shows to the desired maximum temperature. (Standard adjustment 190°C).

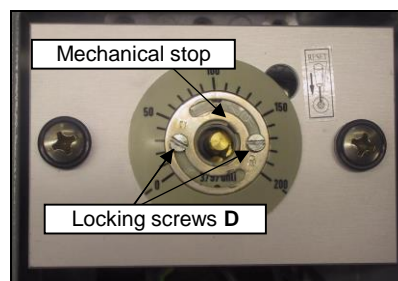
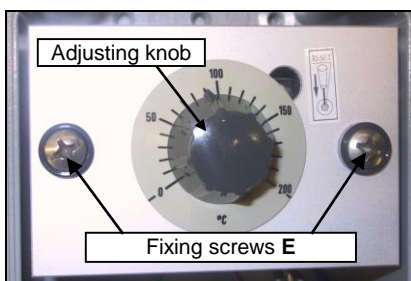

Figure 23 Adjustment of the mechanical stop at the thermostat controller

If you use gas sample probes with temperature sensor (PT100 or thermoelement) instead of the thermostat, lead the sensor connecting cable with the heating cartridge through the cable gland. In order to do this, put the connecting cable into the corrugation of the sealing rings and the two metal rings.

18 SWITCHING OFF

CARE! Before switching off, i.e. switching off the heating, the gas flow via probe has to be stopped and the probe has to be flushed with inert gas or air in order to avoid condensation of aggressive components from the process gas.

19 SPARE PART LIST

Wear, tear and replacement part requirements depend on specific operating conditions. The recommended quantities are based on experience and are not binding.

Gas sample probe SP2000, SP2000-H, SP2300-H, SP2400-H					
(C) Consumable parts (R) Recommended spare parts (S) Spare parts					
		Recommended quantity being in operation [years]			
Part No.	Indication	C/R/S	1	2	3
90 S 0020	Filter element S-2K150 , ceramic, 2 µm, 150 mm	C	6	12	18
90 F 0125	Filter element F-0,1GF150 , glass fiber, 0,1 µm, 150 mm	C	6	12	18
93 S 2083	Special spun-glass hightemperature resistant for probes with /FW insert. Contents:1000g.	C	1	2	3
93 S 0045	Gasket (30) for filter element. Material: Viton.	R	4	8	12
93 S 0055	Gasket (30) for filter element. Material: graphite.	R	4	8	12
93 S 0046	Gasket (30) for filter element. Material: PTFE	R	4	8	12
93 S 0020	O-ring (39) for lid. Material: Viton.	R	2	4	8
93 S 0025	O-ring (55) for lid. Material: Viton.	R	2	4	8
93 S 0030	Gasket (69) for lid SP2000-H320. Material graphite	R	2	4	8
93 S 0035	Sealing spiral o-ring (39) for SP2000/7aT. Material: PTFE.	R	1	2	3
93 S 0040	Sealing spiral o-ring (55) for SP2000/7aT. Material: PTFE.	R	1	2	3
90 S 2080	Gasket 3/4" for spun glass cartridge FW, insitu probe tubes, pre-filter V20, extension tubes. Material: Novapress.	R	1	2	3
90 S 2077	Flange gasket DN65 PN6B (67). Material: Novapress.	R	1	1	1
90 S 2075	Flange gasket set for DN65 PN6B consisting of gasket (67) and a set of screws M12x60.	S	1	1	1
93 S 0010	Thermostat (0-180°C), with over-temperature limiter and low-temperature alarm for probe series SP.	R	-	-	1
93 S 0011	Thermostat (0-320°C), with over-temperature limiter and low-temperature alarm for probe series SP.	R	-	-	1
93 S 0015	Heating cartridge for SP2000-H, L=160mm, 230V/800W.	R	-	-	1
93 S 0017	Heating cartridge for SP2000-H, L=160mm, 115VAC/800W.	R	-	-	1
93 S 0059	PT100 sensor (spare)	R	-	-	1
93 S 0060	Spare thermoelement Fe-CuNi	R	-	-	1
93 S 0061	Spare thermoelement NiCr-Ni	R	-	-	1

20 CONNECTION AND MOUNTING DATA

Gas sample probe type	SP2000	SP2000-H	SP2300-H	SP2400-H
Dimensions B x H x T	340 x 260 x 345			
Material filter housing	SS316Ti*		PTFE-Ko	Titanium
Sealing materials	FPM* /7aT** = PTFE /H320** = Graphite			
Material probe flange gasket	Novapress			
Low temperature alarm contact	Switching capacity: 250V, 3A~, 0,25A=, switching point: ΔT 30°C			
Connection gas outlet / second gas outlet	1 x ¼"NPTi* for tube connection Ø 6, 8 or 10mm**, /H320** = 6mm* or 8mm**			
Blow back-/test gas connection	¼"NPTi*, /R** and H320** = tube Ø 6mm			
Power supply / wattage / fuse protection	230V 50/60Hz, 800W, /115V** = 115V 60Hz, 800W fuse protection 10A			
Electrical connection	Terminals max. 4mm ² , 2 x M20 x 1,5 cable gland			
Mounting flange	DN65 PN6, form B, 1.4571*, >DN or ANSI possible**, /HP**=DN50 PN25			

Controller type	70304G
Dimensions B x H x T	150 x 250 x 145
Status signal output	Low temperature alarm: 1 contact NO, potential free. Switching capacity max. 250VAC 3A
Electrical connection	Terminals max. 4mm ² , 4 x M20 x 1,5 cable gland
Power supply	115V 50/60Hz 1725VA, 230V 50/60Hz 3450VA

Pneumatic ball valve drive type	MS1 and MS3
Connection control line	G1/4 " i

Electrical ball valve drive type	EA
Status signal output	Position end switch 250VAC, 11A AC, 0,25A DC** (mains potential)
Electrical connection	Terminals max. 4mm ² , 2 x M20 x 1,5 cable glands
Power supply	230V 50Hz, 140W (115V 60Hz or 24V DC)
Status signal potential free**	2 x position end switch, potential free, open/closed, 250V, 16A

Solenoid valve units type	2	3
Dimensions B x H x T	270 x 270 x 150	270 x 270 x 190
Pneumatic connections	2 x control air G1/4"i 2 x blow back G3/8"i	2 x control air G1/4"i 3 x blow back G3/8"i
Elektrical connections	Terminals max. 4mm ² , 3 x M20 x 1,5 cable gland	
Power supply	115V 50/60Hz 20W, 230V 50/60Hz 20W, 24V DC 20W	

* Standard

** optional

21 APPENDIX

Dimensions / construction, drawing no. : **22551010, 22551020**

Sampling possibilities, drawing no. : **22551040, 22091024**

Ball valve options and test gas feeding / blow back, drawing no. : **22551110**

3/2-way ball valve and pneumatic drive, drawing no. : **2255/05/0/02.98**

3/2-way ball valve and pneumatic drive, drawing no. : **2255/05/1/02.98**

3/2-way ball valve and pneumatic drive, drawing no. : **2255/05/2/02.98**

3/2-way ball valve and pneumatic drive, drawing no. : **2255/05/3/02.98**



More product documentation is available on our Internet catalogue:

www.mc-techgroup.com

- Sample tubes series **SP**
Document: **2-1.1.0.6**
- Prefilter series **SP**
Document: **2-1.1.0.8**

Gas sample probe SP2000-H / Basic Version

2-1.1.1

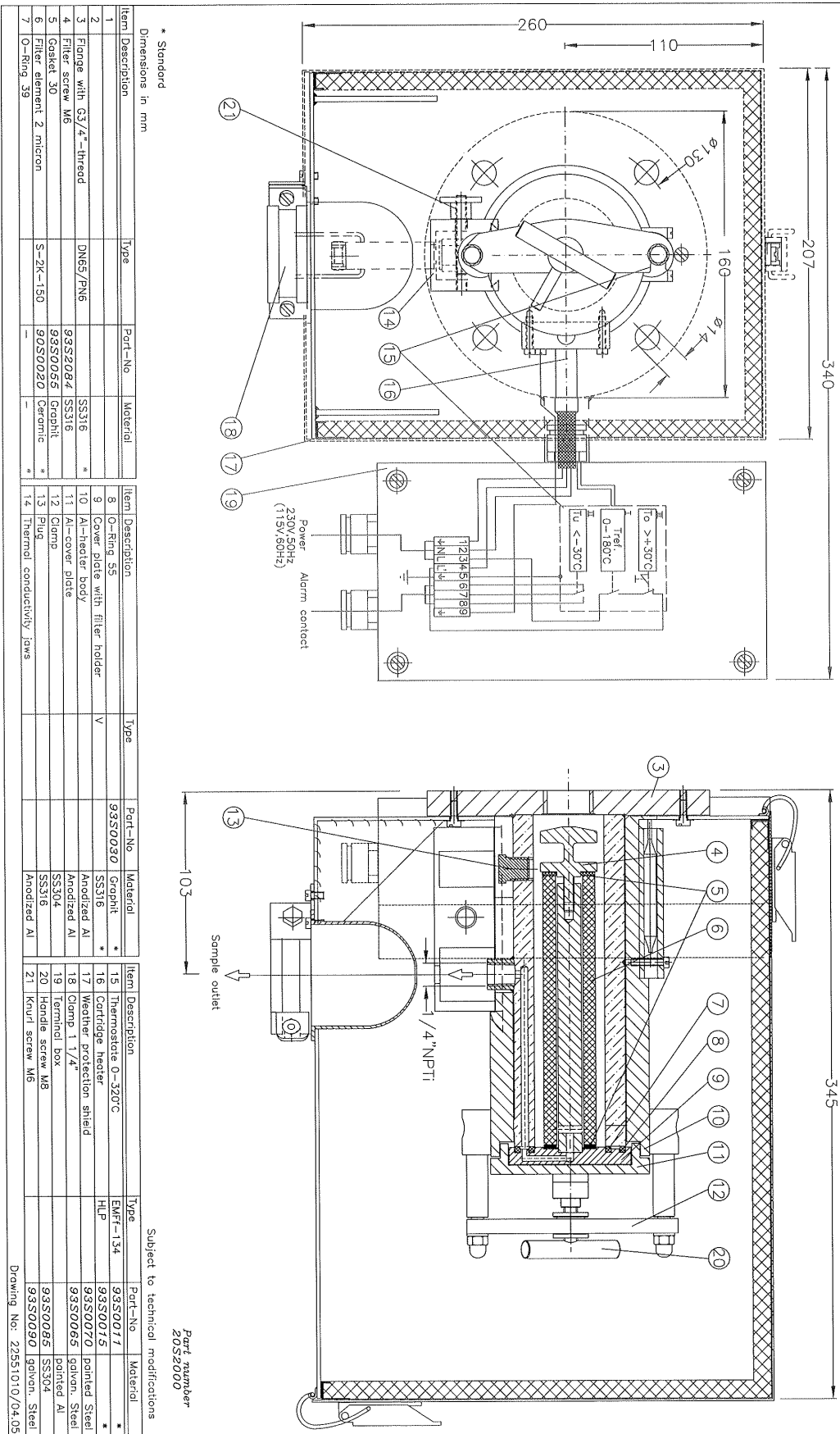

Figure 24 SP2000-H basic version

Fig-

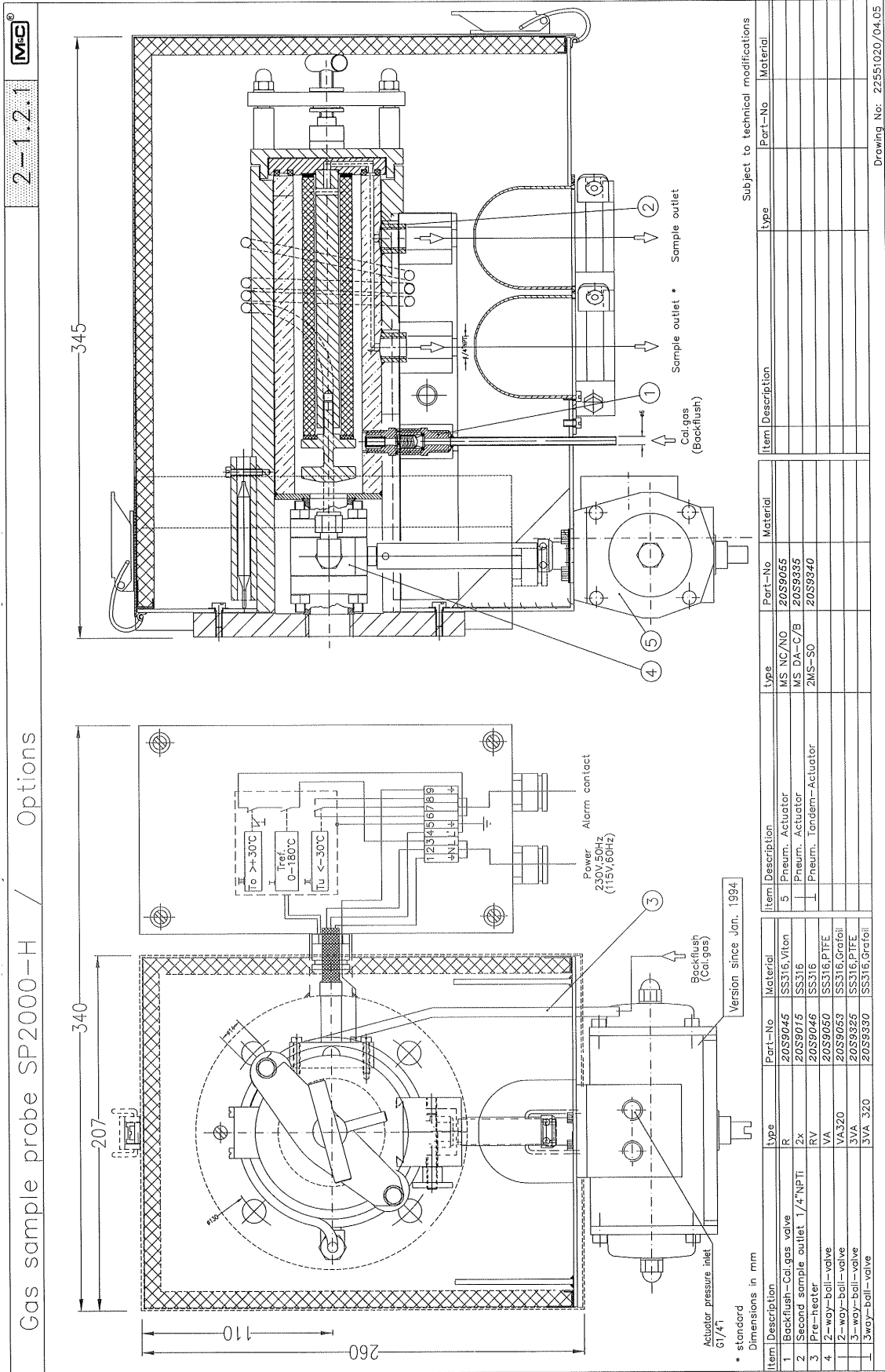

Figure 25

SP2000-H with options

Fig-

Gas sample probe SP2000-H / High temperature insitu probe max 1800°C

2-1.6.1

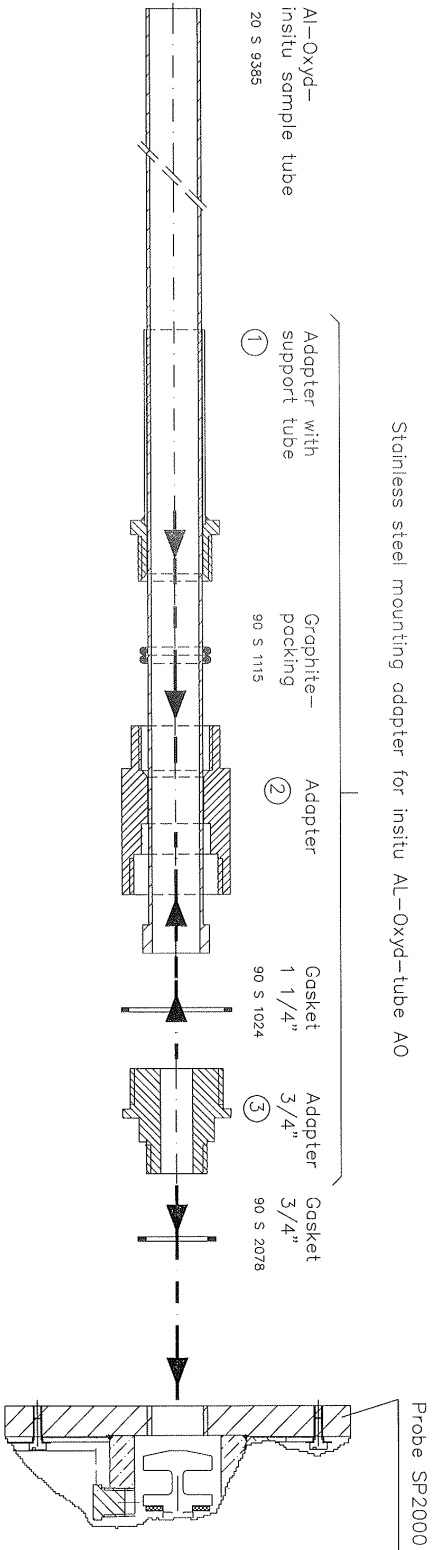

Part number
Dimensions in mm
Subject to technical modifications

Drawing No: 22551040/03.96

Figure 26 High temperature tube aluminium oxide AO

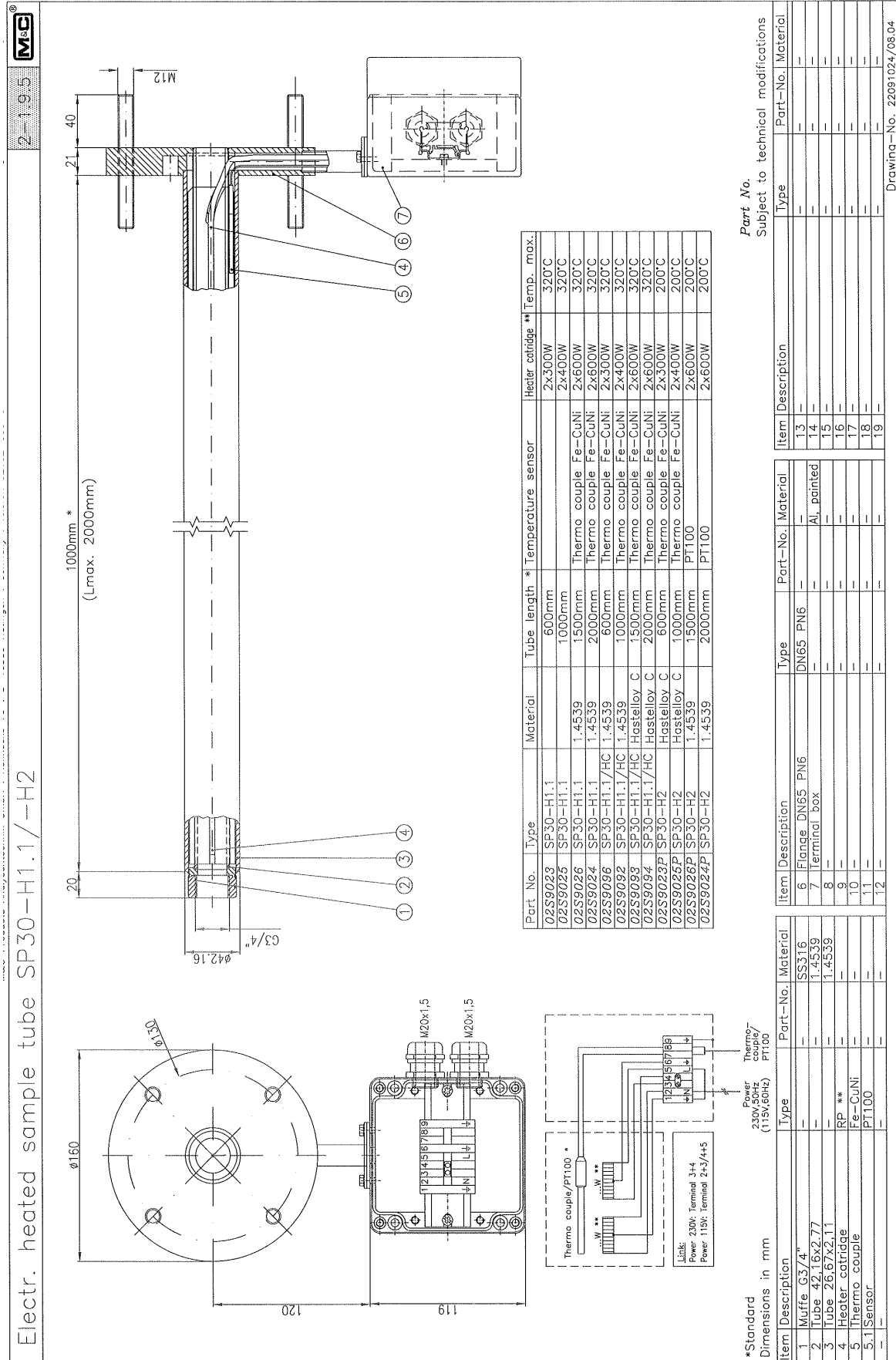

Figure 27 Heated sample tubes SP30-H...

Gasentnahmesonde/Sample probe SP2000-H.../...VA...		2-1.3.5	M&C®
Version mit 2-Wege-Kugelhahn zum Absperren für Prüfgasaufgabe oder Service Anwendungsempfehlung: Filterwechsel, Reinigung usw. bei über-/Unterdruck, giftigen, korrosiven Gasen.			
Type with 2-way ball valve to shut off for calibration or maintenance. Recommended application: filter changing, cleaning etc. at over- or underpressure conditions, poisonous or corrosive samples.			
Funktion / function	Version / type	2-Wege-Kugelhahn VA	/2-way ball valve VA
2-Wege-Kugelhahn VA zum Absperren der Gasentnahmesonde vom Prozess.	Gasentnahmesonde / Sample probe SP2000-H/VA		
2-way ball valve VA for shut off the sample probe from process.			
2-Wege-Kugelhahn VA zum Absperren der Gasentnahmesonde vom Prozess Prüfgasaufgabe über Rückschlagventil R.	Gasentnahmesonde / Sample probe SP2000-H/R/VA		
2-way ball valve VA for shut off the sample probe from process. Calibration gas trough checkvalve R.			
2-Wege-Kugelhahn VA mit pneum. Antrieb MS zum aut. Absperren der Gasentnahmesonde vom Prozess.	Gasentnahmesonde / Sample probe SP2000-H/VA/MS-NC (NO)		
2-way ball valve VA with pneum. actuator MS for aut. shut off the sample probe from process.	Version 320°C: pneum. Antrieb MS-DA mit 2.Steuermagnetventil (P=>6,5bar) / Type 320°C: pneum. actuator MS-DA with 2. control solenoid valve (P=>6,5bar)		
2-Wege-Kugelhahn VA mit pneum. Antrieb MS zum aut. Absperren der Gasentnahmesonde vom Prozess. Prüfgasaufgabe über Rückschlagventil R.	Gasentnahmesonde / Sample probe SP2000-H/R/VA/MS-NC (NO)		
2-way ball valve VA with pneum. actuator MS for aut. shut off the sample probe from process. Calibration gas trough checkvalve R.	Zeichn.-Nr./ Drawing No: 22551110/07.05		

Gasentnahmesonde/Sample probe SP2000-H.../...VA...		2-1.3.5	M&C
Version mit 3-Wege-Kugelhahn zum Absperrn für Rückspülen, Prüfgasgabe oder Service Anwendungsempfehlung: Filterwechsel, Reinigung usw. bei Über-/Unterdruck, giftigen, korrosiven Gasen.			
Type with 3-way ball valve to shut off for backflush, calibration or maintenance. Recommended application: filter changing, cleaning etc. at over- or underpressure conditions, poisonous or corrosive samples.			
Funktion / function	Version / type	3-Wege-Kugelhahn 3VA / 3-way ball valve 3VA	
3-Wege-Kugelhahn 3VA zum Absperrn der Gasentnahmesonde vom Prozess. Rückspülung und Prüfgasgabe über Kugelhahn 3VA.	Gasentnahmesonde / Sample probe SP2000-H/3VA		
3-way ball valve 3VA to shut off the sample probe from process. Backflush and calibration through 3-way ball valve 3VA.		1 = Messen/Measuring 2 = Absperrn / Rückspülen Shut off / Backflush 3 = Absperrn / Prüfgasgabe Shut off / Calibration	
3-Wege-Kugelhahn 3VA mit pneum. Antrieb MS (0-90°) zum autom. (Fernsteuerung) Absperrn der Gasentnahmesonde vom Prozess. Rückspülung (MS-B) oder Prüfgasgabe (MS-C) über Kugelhahn 3VA.	Gasentnahmesonde / Sample probe SP2000-H/3VA/MS-C (MS-B)		
3-way ball valve 3VA with pneum. actuator MS (0-90°) to shut off the sample probe from process automatically. Backflush (MS-B) or calibration (MS-C) through 3-way ball valve 3VA.		1 = Messen/Measuring 2 = Absperrn / Rückspülen Shut off / Backflush 3 = Absperrn / Prüfgasgabe Shut off / Calibration	
Version 320°C.: pneum. Antrieb MS-DA mit 2.Steuermagnetventil (P=>6,5bar) / Type 320°C.: pneum. actuator MS-DA with 2. control solenoid valve (P=>6,5bar)			
3-Wege-Kugelhahn 3VA mit pneum. Antrieb MS (0-90°) zum autom. (Fernsteuerung) Absperrn der Gasentnahmesonde vom Prozess. Rückspülung über Kugelhahn 3VA. Prüfgasgabe über Rückschlagventil R.	Gasentnahmesonde / Sample probe SP2000-H/R/3VA/MS-B		
3-way ball valve 3VA with pneum. actuator MS (0-90°) to shut off the sample probe from process automatically. Backflush through 3-way ball valve 3VA. Calibration through check valve R.		1 = Messen/Measuring 2 = Rückspülen / Prüfgasgabe Backflush / Calibration	
3-Wege-Kugelhahn 3VA320 mit pneum. Antrieb 2MS-SO (0-90-180°) zum autom. Absperrn der Gasentnahmesonde vom Prozess. Rückspülung und Prüfgasgabe über Kugelhahn 3VA.	Gasentnahmesonde / Sample probe SP2000-H320/3VA320/2MS-SO		
3-way ball valve 3VA320 with pneum. actuator 2MS-SO (0-90-180°) to shut off the sample probe from process automatically. Backflush and calibration through 3-way ball valve 3VA.		1 = Messen/Measuring 2 = Absperrn / Rückspülen Shut off / Backflush 3 = Absperrn / Prüfgasgabe Shut off / Calibration	
Zeichn.-Nr./ Drawing No: 22551110/BL2/03.05			

Figure 28 Test gas feeding and blow back possibilities

Gas sample probe SP2000-H with 3/2-way-ball-valve and pneumatic actuator; different versions and functions



Version SP2000-H/3VA/MS-NC-B

Normal position NC-B: "BACK FLUSH TO PRE FILTER"
 (Manufacturers adjustment) Pneumatic actuator unpressurized, ball valve position "CLOSED"
 the little bore is pointing to sample inlet

Operating position "SAMPLE"
 Pneumatic actuator pressurized,
 ball valve position "OPEN"

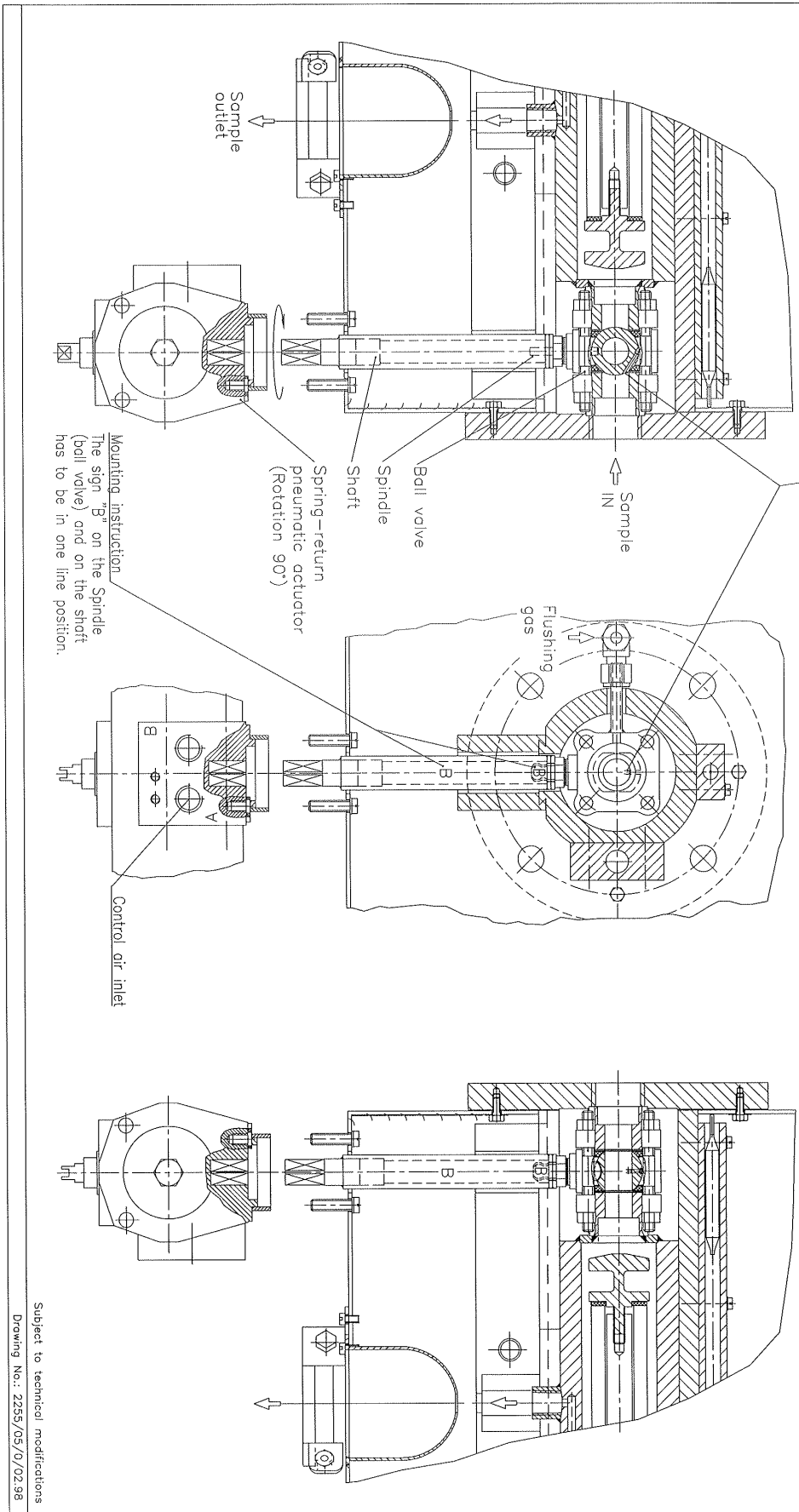

Figure 29 SP2000-H/3VA/MS-NC-B

Gas sample probe SP2000-H with 3/2-way-ball-valve and pneumatic actuator; different versions and functions

Version SP2000-H/3VA/MS-NC-C

Normal position NC-C: "CAL. GAS or BACK FLUSH TO ANALYSIS"

(Manufacturers adjustment) Pneumatic actuator unpressurized, ball valve position "CLOSED", the little bore is pointing to filter housing

Operating position "SAMPLE"

Pneumatic actuator, pressurized, ball valve position "OPEN"

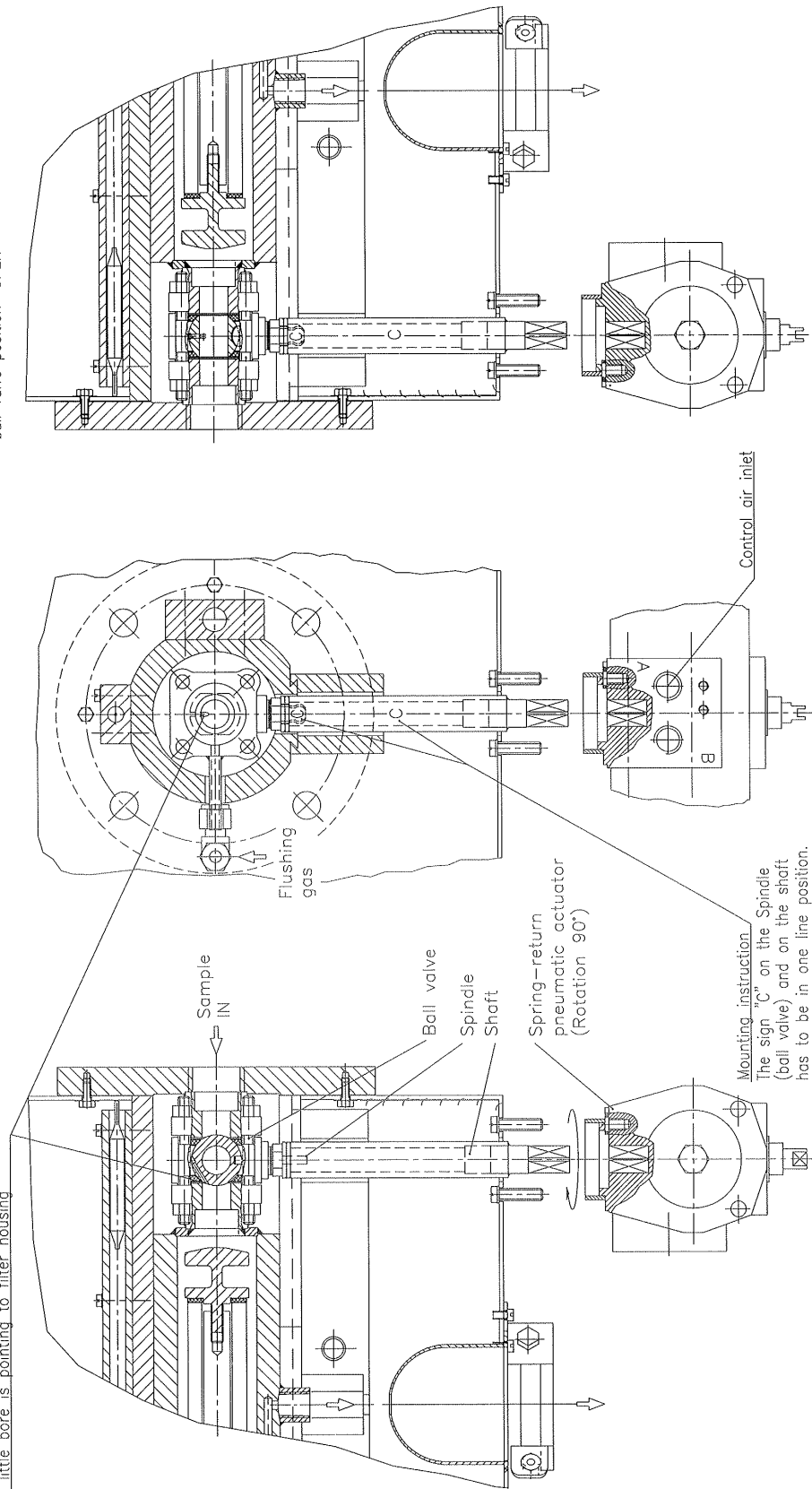

Subject to technical modifications
Drawing No.: 2255/05/1/02.98

Figure 30 SP2000-H/3VA/MS-NC-C

Gas sample probe SP2000-H with 3/2-way-ball valve and pneumatic actuator; different versions and functions

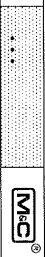

Version SP2000-H/3VA/MS-NO-B

Normal position NO-B: "SAMPLE"
(Manufacturers adjustment)
Pneumatic actuator unpressurized, ball valve position "OPEN"

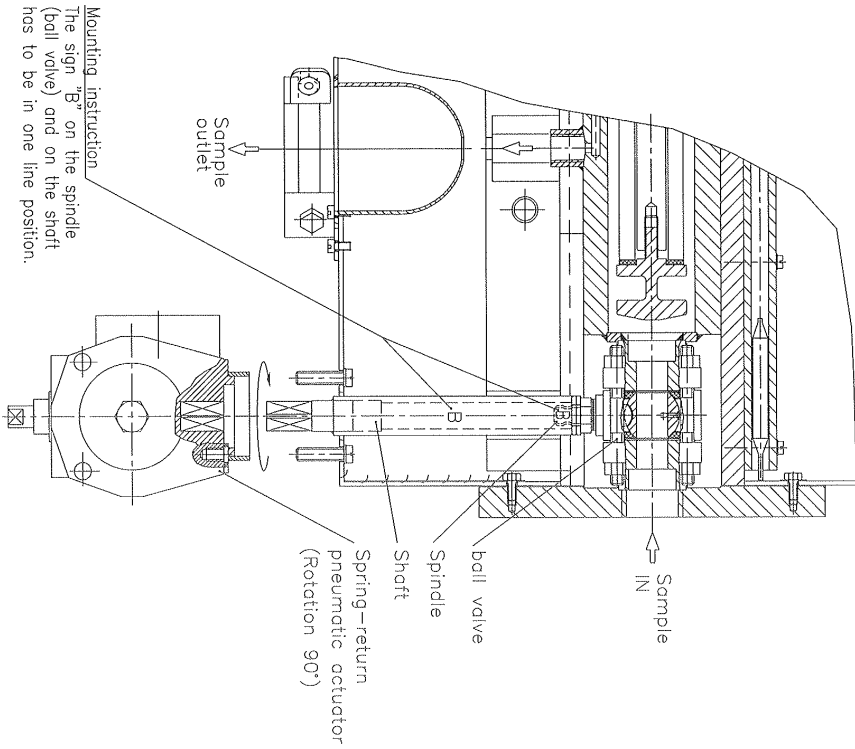

Operating position "BACK FLUSH TO PRE FILTER"
Pneumatic actuator pressurized, ball valve position "CLOSED",
the little bore is pointing to sample inlet.

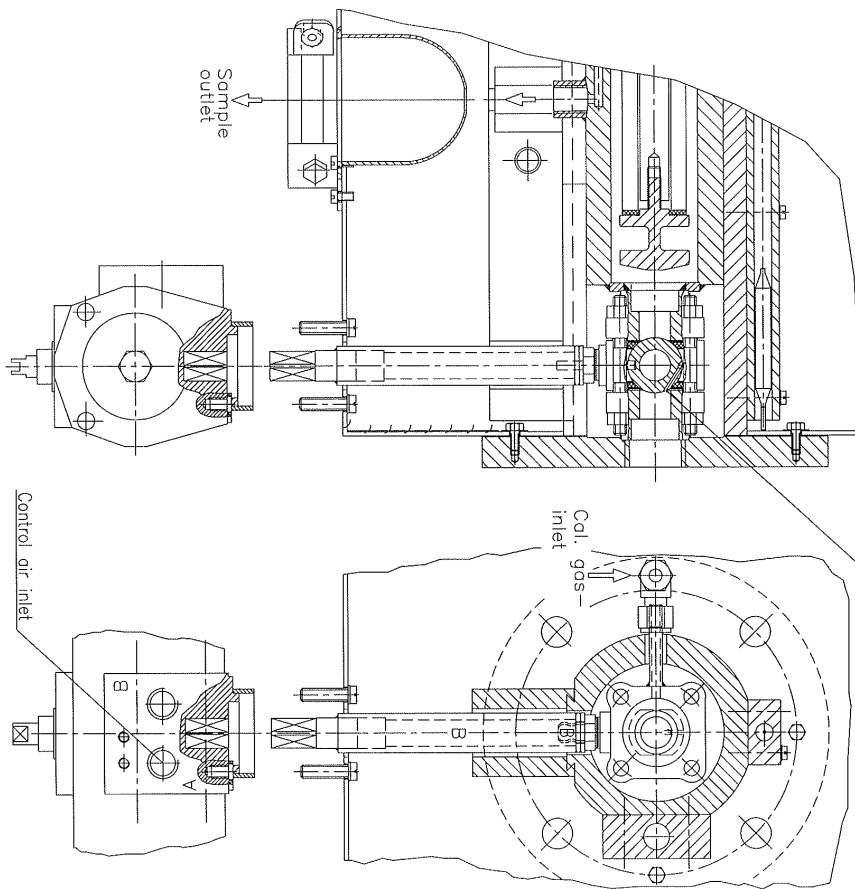

Subject to technical modifications
Drawing No.: 2255/05/2/02.98

Figure 31 SP2000-H/3VA/MS-NO-B

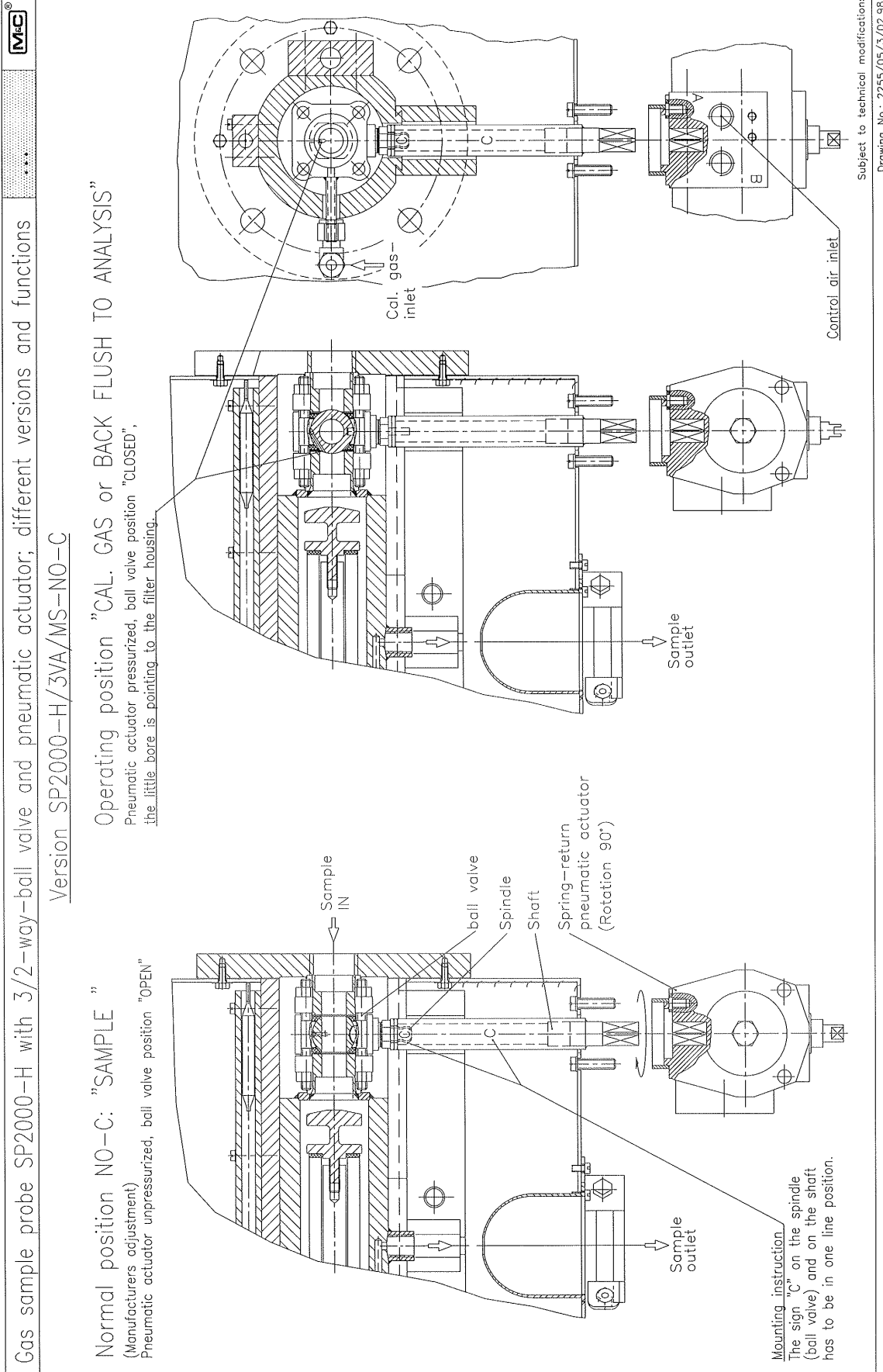

Figure 32 SP2000-H/3VA/MS-NO-C